



Maintenance Manual 14P

Meritor Tire Inflation System (MTIS™)

Standard MTIS™

MTIS™ with the ThermALERT™ System

Revised 10-17

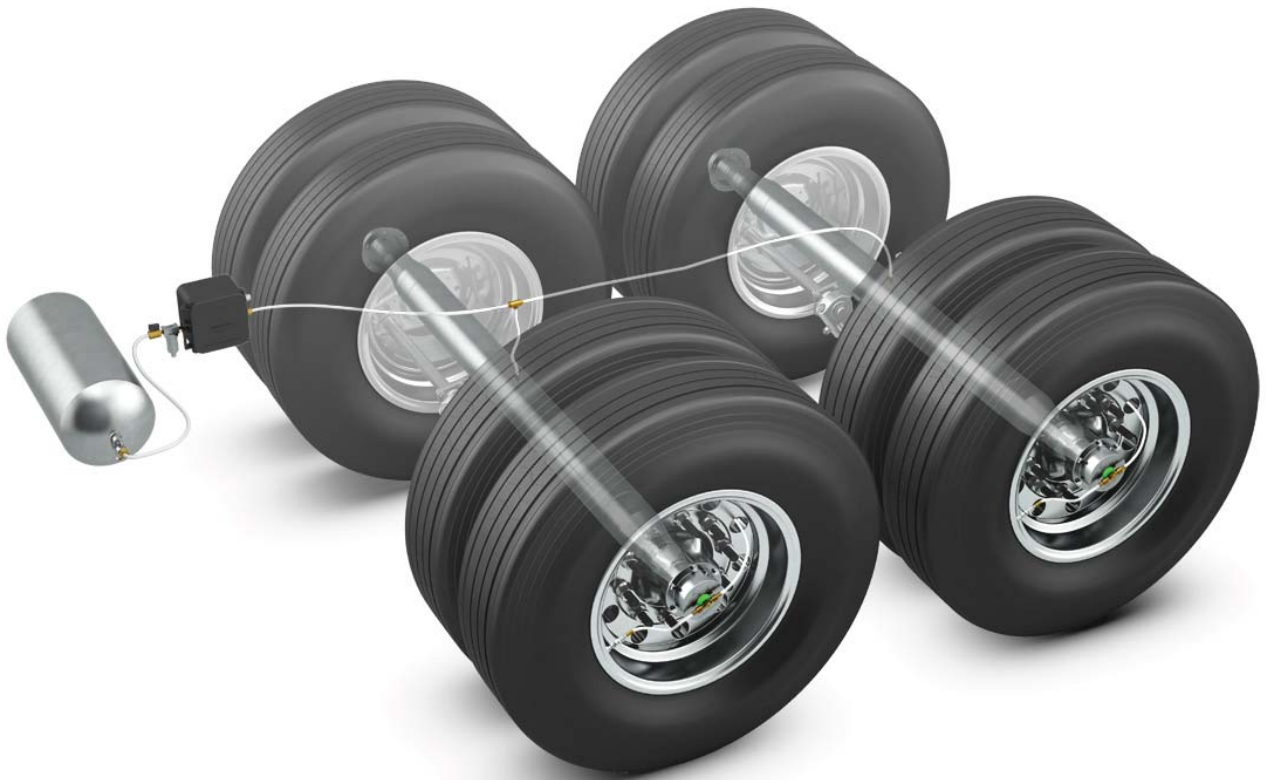

Service Notes

About This Manual

This manual provides installation and maintenance procedures for the Meritor Tire Inflation System (MTIS™). Use the procedures in this manual to install the standard tire inflation system and the tire inflation system with ThermALERT™ on either new trailer axles at original equipment manufacturers or in-service trailer axles at fleets.

NOTE: ThermALERT became a standard feature in all MTIS kits starting October 1, 2017.

Before You Begin

1. Read and understand all instructions and procedures before you begin to service components.
2. Read and observe all Warning and Caution hazard alert messages in this publication. They provide information that can help prevent serious personal injury, damage to components, or both.
3. Follow your company's maintenance and service, installation, and diagnostics guidelines.
4. Use special tools when required to help avoid serious personal injury and damage to components.

Hazard Alert Messages and Torque Symbols

WARNING

A Warning alerts you to an instruction or procedure that you must follow exactly to avoid serious personal injury and damage to components.

CAUTION

A Caution alerts you to an instruction or procedure that you must follow exactly to avoid damage to components.

 This symbol alerts you to tighten fasteners to a specified torque value.

How to Obtain Additional Maintenance, Service and Product Information

Visit Literature on Demand at meritor.com to access and order additional information.

Contact the Meritor OnTrac™ Customer Call Center at 866-668-7221 (United States and Canada); 001-800-889-1834 (Mexico); or email OnTrac@meritor.com.

If Tools and Supplies are Specified in This Manual

Contact Meritor's Commercial Vehicle Aftermarket at 888-725-9355 to obtain Meritor tools and supplies.

For Grainger tools, visit their website at www.grainger.com to locate a branch near you.

Information contained in this publication was in effect at the time the publication was approved for printing and is subject to change without notice or liability. Meritor Heavy Vehicle Systems, LLC, reserves the right to revise the information presented or to discontinue the production of parts described at any time.

pg. 1	Section 1: Introduction	pg. 45	Section 7: Special Tools
	Overview		Special Tools
2	The Standard Meritor Tire Inflation System (MTIS)		Tire Inflation System
	The MTIS with the ThermALERT System		
	If the MTIS Warning Light Comes ON When the Air System is Charging		
	If the MTIS Warning Light Comes ON During Operation		
3	Warning Light		
	Wheel-End Assembly		
	Controls		
4	Installation and Maintenance Information		
6	Section 2: Assembly and Installation		
	Installation on Non-Prepped Axles		
	Sequence for Installing a Standard MTIS System and an MTIS System with a ThermALERT System		
	Axle Air Fitting		
7	Prepare a Hollow Spindle Axle to Install the Standard MTIS and MTIS with the ThermALERT System		
12	Prepare a Solid Spindle Axle to Install Standard MTIS Without the ThermALERT System		
16	Stator		
17	Wheel-End Components		
19	Air Components		
23	Electrical Components		
25	Wheel-End Oil		
26	Standard MTIS and ThermALERT System Decals		
27	Section 3: Check System Operation		
	Check System Operation		
29	Control Box Adjustment Procedures		
32	MTIS Allowable Leak Rate and Test		
	Check the Hose Connections for Leaks		
33	Check the Wheel End for Air Leaks		
36	Section 4: Pre-Service Check		
	Pre-Service Check		
38	Section 5: Inspection and Maintenance		
	Tire Inflation System Inspection Interval Guidelines		
	Inspection		
	Warning Light		
39	Tires		
	Component Removal and Installation		
	Turn the System OFF		
40	Remove and Replace the Tires		
41	Hose Check Valves		
	Remove the Thru-Tee Before Installing a Hubcap		
43	Section 6: Troubleshooting		
	Diagnostics		

Overview

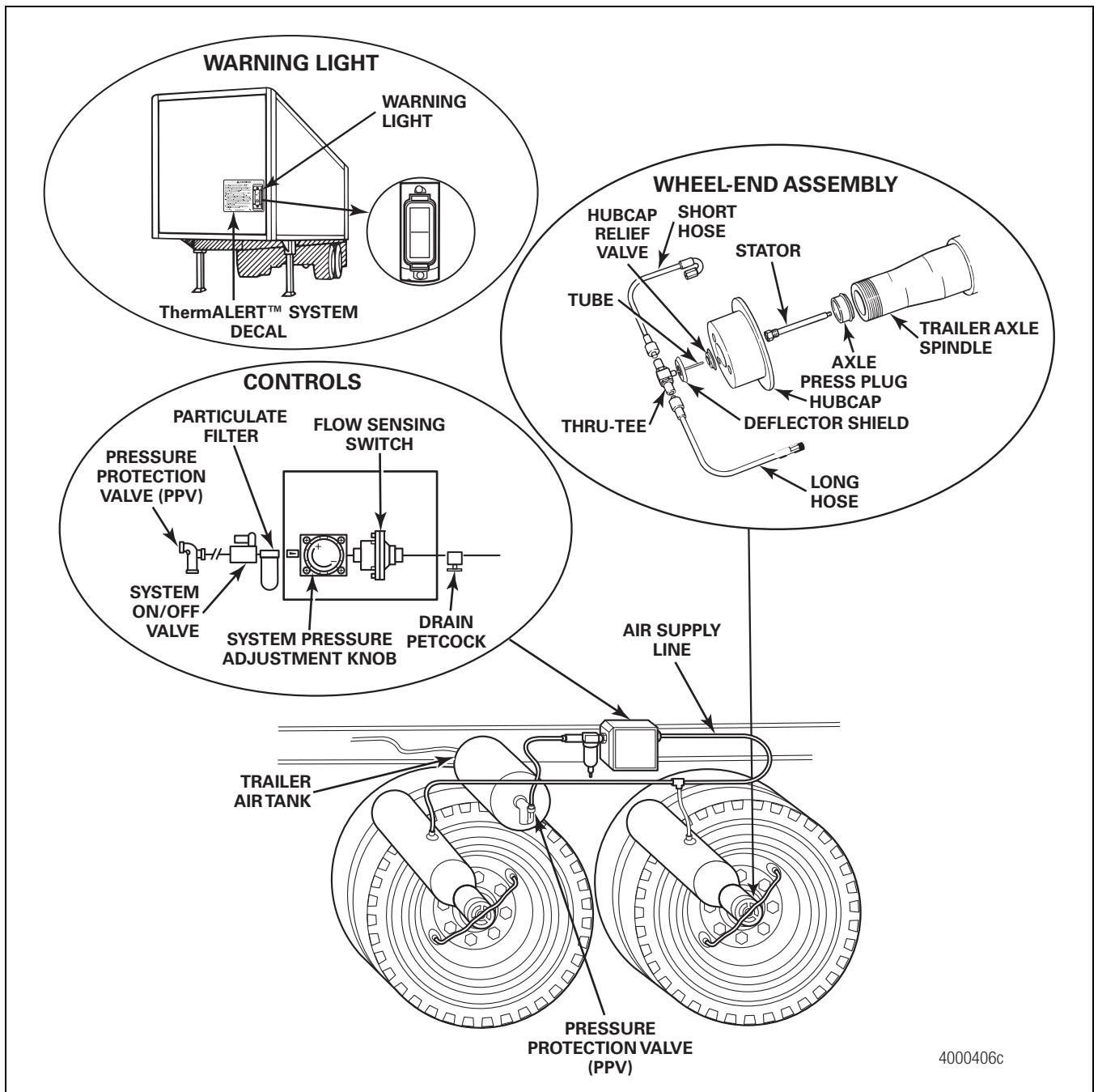

4000406c

Figure 1.1

1 Introduction

The Standard Meritor Tire Inflation System (MTIS)

The Meritor Tire Inflation System (MTIS) uses compressed air from the trailer to inflate any tire that falls below the system air pressure setting during operation.

Air from the existing trailer air supply is routed to a control box, then into each axle. Refer to Figure 1.1. The axles act as conduits to distribute air through rotary union assemblies at the spindle ends, which then distribute air to each tire as needed. If a tire is leaking, check valves in the tire delivery lines prevent loss of pressure in the remaining tires.

The MTIS warning light on the front of the trailer will come ON to alert you if there is an excessive amount of air flow through the system, which can be caused by a leaking tire or a loose connection, or both. If the warning light comes ON during operation, immediately find a safe place to bring the tractor and trailer to a complete stop. You must repair components that caused the air leak before returning the vehicle to service.

Standard MTIS does not eliminate the need to perform tire inspections or wheel-end maintenance at regularly-scheduled intervals.

The MTIS with the ThermALERT System

NOTE: ThermALERT became a standard feature in all MTIS kits starting October 1, 2017.

The MTIS with the ThermALERT system detects when air is escaping from the axle's thermal plug and out through the hubcap relief valve, which occurs if a wheel end is operating at an abnormally high temperature. The MTIS warning light will come ON to alert you to immediately find a safe place to bring the tractor and trailer to a complete stop.

Air escaping from the hubcap relief valve produces an audible noise, which helps you to identify the wheel end that is overheated. Do not operate the trailer until the components are repaired.

The MTIS ThermALERT system does not eliminate the need to perform tire inspections at regularly-scheduled intervals.

If the MTIS Warning Light Comes ON When the Air System is Charging

When you start a vehicle, the MTIS warning light initially may come ON while the air system is charging. However, if the warning light stays ON for more than 10 minutes, a tire may be damaged and losing air pressure. Inspect the tires for damage and air leaks. Repair damaged or leaking tires before returning the vehicle to service.

If the MTIS Warning Light Comes ON During Operation

WARNING

If the ThermALERT system activates during vehicle operation, you must repair or replace components that caused the wheel end to overheat before returning the vehicle to service. Upon activation, the thermal plug must be removed and replaced. The thermal plug is not reusable. Otherwise, the warning light will continue to remain ON during vehicle operation, even though the wheel end has been repaired. If you ignore the warning light, and another wheel end overheats during operation, serious personal injury and damage to components can result.

The MTIS with the ThermALERT system detects when air is escaping from the axle's thermal plug and out through the hubcap relief valve, which occurs if a wheel end is operating at an abnormally high temperature. The MTIS warning light will come ON to alert you that air flow through the system is excessive.

1. Immediately find a safe place to bring the tractor and trailer to a complete stop.
2. Inspect the trailer hubs for air leaks.
3. Listen for the ThermALERT system's audible sound at the wheel end. If you hear the sound, the wheel end is overheated. Do not operate the trailer until the wheel-end components are repaired. If a wheel end overheats during operation, it can separate from the vehicle. Serious personal injury and damage to components can result.
4. If you do not hear the ThermALERT system's audible sound at the wheel end, inspect the tires for damage. Repair damaged or leaking tires before returning the vehicle to service.

Warning Light

A warning light mounted to the trailer comes ON when the system delivers an excessive amount of air due to a leaking tire, tire inflation system component, or if equipped with a ThermALERT system, a wheel end operating at an abnormally high temperature.

An MTIS system with a ThermALERT system will also have a ThermALERT system decal installed at the warning light on the trailer.

Wheel-End Assembly

Stator and Thru-Tee

The stator is located inside the axle spindle and the thru-tee is attached to the hubcap. Pressurized air passes from the stationary axle interior to the rotating hub through a tube extending from the thru-tee into the stator. Dynamic seals, located in the thru-tee and stator, allow rotation without loss of air pressure.

Hoses

A hose is a flexible valve stem extension which mechanically opens the tire valve core and allows air to pass into a tire. A check valve located at the knurled end of a hose allows air to flow in only one direction-towards the tire. This protects each tire from loss of air pressure if the tire inflation system, or any tire, loses air pressure during operation.

Deflector Shield

The deflector shield helps prevent any contaminants such as dirt and water from entering the wheel end.

Hubcaps

⚠ CAUTION

The Meritor Tire Inflation System (MTIS) that is equipped with the ThermALERT system uses hubcaps with six vent tubes. These hubcaps are not interchangeable with the three-vent tubes. Damage to components can result if you install the incorrect hubcaps.

The hubcaps for MTIS with and without the ThermALERT system use vents to prevent pressure buildup in the wheel end, as well as a deflector shield to help prevent contaminants from entering the wheel end.

Hubcaps for oil-lubricated wheel ends typically have a fill plug for adding lubricant.

Axle Press Plug

The axle press plug is used in axles with hollow spindles to seal off the pressurized axle interior from the wheel end and provide a means of holding and securing the stator.

Refer to Figure 1.2 for a comparison of the standard MTIS axle press plug and the ThermALERT system axle press plug.

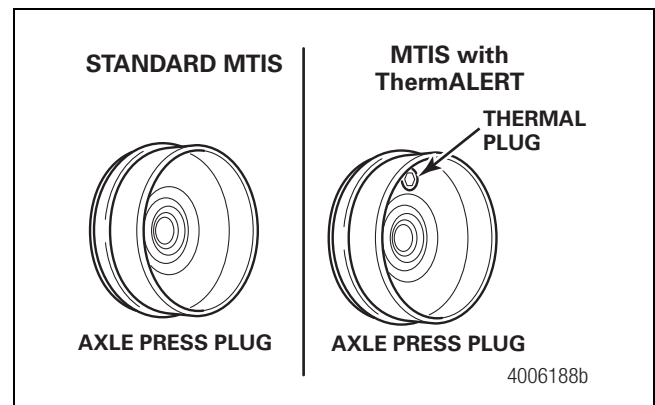

Figure 1.2

NOTE: ThermALERT became a standard feature in all MTIS kits starting October 1, 2017.

Controls

Particulate Filter

The particulate filter removes contaminants from the air system.

Flow Sensing Switch

⚠ WARNING

The standard MTIS can have a control box with either a black flow sensing switch or a grey flow sensing switch. Both control boxes mount to the trailer in the same way. However, MTIS equipped with a ThermALERT system must have a control box with a grey flow sensing switch, which is more sensitive to air flow than the black switch.

If a ThermALERT system has a control box with a black flow sensing switch, replace it with a control box that has a grey switch. Otherwise, the warning light may not come ON if a wheel end overheats. Serious personal injury and damage to components can result.

1 Introduction

The flow sensing switch illuminates the warning light when the system delivers an excessive amount of air to either a leaking tire, a leaking tire inflation system component; or if equipped with the ThermALERT system, a wheel end operating at an abnormally high temperature.

The control box for the standard MTIS can include a flow sensing switch that is either black or grey. The control box for the MTIS with the ThermALERT system must include a grey flow sensing switch. Both control boxes mount to the trailer in the same way.

Drain Petcock

The drain petcock is used to manually exhaust pressure from the tire inflation system. This enables you to perform maintenance on either the trailer axle components or the tire inflation system.

System Pressure Adjustment Knob

The system pressure adjustment knob is used to adjust system air pressure. The system air pressure should be adjusted to the customer's recommended tire pressure.

System On/Off Valve

The system on/off valve allows air delivery to the system and also stops air delivery to the system.

Pressure Protection Valve (PPV)

⚠ CAUTION

Only use the pressure protection valve (PPV) provided in the Meritor Tire Inflation System (MTIS) kit during installation. Do not install any other PPV, which will void Meritor's warranty and can damage components.

The pressure protection valve (PPV) ensures that air is available for other trailer functions and maintains air tank pressure if a tire or a tire inflation system component is damaged. During the installation process, only use the PPV provided in the Meritor Tire Inflation System (MTIS) kit.

Installation and Maintenance Information

Use the procedures in this manual to install the tire inflation system on either new trailer axles at original equipment manufacturers or in-service axles at fleets.

The tire inflation system can be installed onto trailer axles manufactured either by Meritor, Holland, Hendrickson, Ingersoll, Dana, Eaton, Sudisa, Fuwa or AXN. When installing the system, follow the maintenance instructions provided by these various manufacturers. For trailer axles manufactured by Meritor, refer to Maintenance Manual 14, Trailer Axles. To obtain this publication, refer to the Service Notes page on the front inside cover of this manual.

Trailer axles may be manufactured with either hollow or solid spindles. The system installation sequence is different depending on the axle type. Please refer to the information in the following sections.

NOTE: Up until September 30, 2017, Meritor provided axle models prepped for installation of the standard tire inflation and the ThermALERT system. As of October 1, 2017, Meritor only provides axle models prepped for installation of MTIS with the ThermALERT system. The system installation sequence is different depending on the axle type. Refer to the information in the following sections.

Hollow Spindle Axle

Most hollow spindle trailer axles have a spindle that's integrally formed out of axle tube material. A welsh plug is pressed into a machined recess in the end of the spindle. If you're unsure of the axle type, contact the axle manufacturer. Figure 1.3.

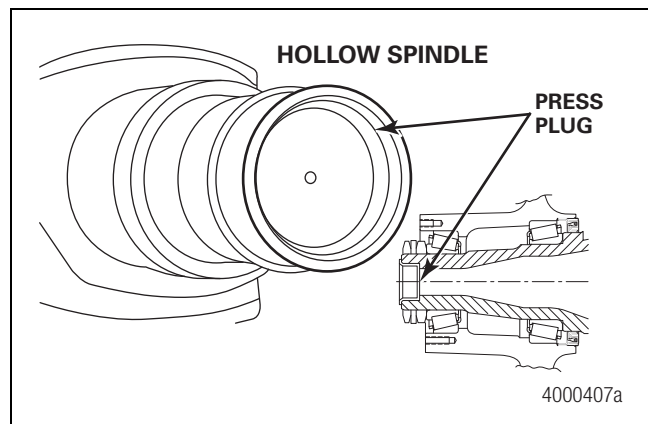

Figure 1.3

Solid Spindle Axle

Most solid spindle trailer axles have a forged spindle welded to the axle tube. If you're unsure of the axle type, contact the axle manufacturer. Figure 1.4.

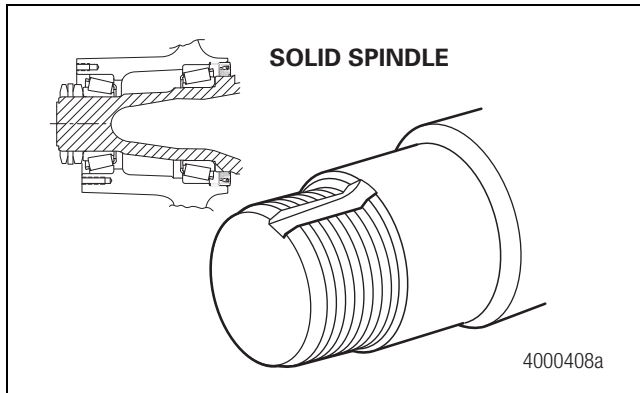

Figure 1.4

Prepped Axle

A trailer axle that has been prepped by Meritor has the following provisions. Other axle manufacturers' prep may vary.

- Debris has been cleaned from the axle interior.
- The standard tire inflation system axle press plug and stator are installed into the axle spindle. Figure 1.5.
- If equipped with the ThermALERT system, the axle press plug with the thermal plug and stator are installed into the axle spindle. The thermal plug must be installed at the 12 o'clock position when the axle is sitting in the running position. Figure 1.6.
- The axle top-center hole is tapped to accept the tire inflation system axle air fitting, and a plug is installed into this hole. Some axle manufacturers may select an alternate location for this hole. Figure 1.7.

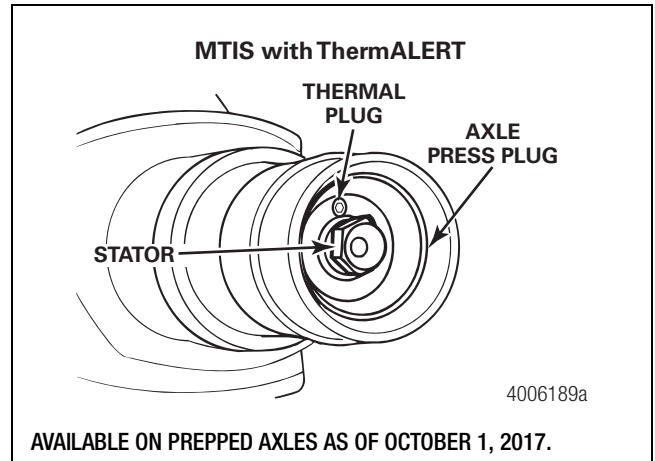

Figure 1.6

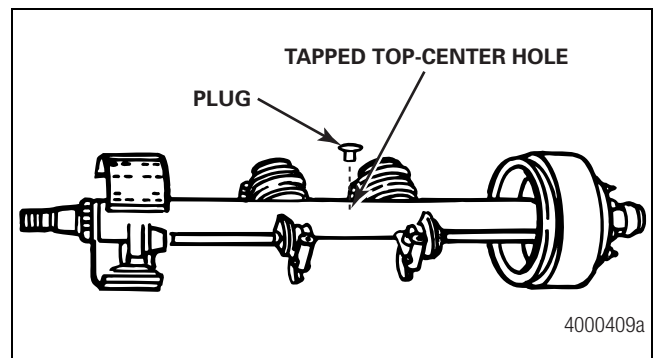

Figure 1.7

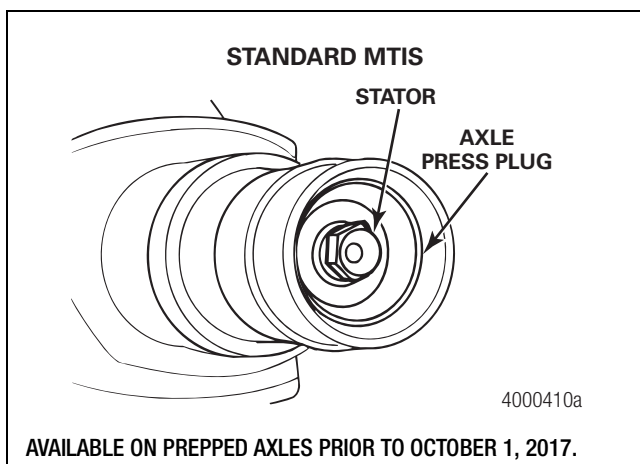

Figure 1.5

2 Assembly and Installation

Hazard Alert Messages

Read and observe all Warning and Caution hazard alert messages in this publication. They provide information that can help prevent serious personal injury, damage to components, or both.

⚠ WARNING

To prevent serious eye injury, always wear safe eye protection when you perform vehicle maintenance or service.

Park the vehicle on a level surface. Block the wheels to prevent the vehicle from moving. Support the vehicle with safety stands. Do not work under a vehicle supported only by jacks. Jacks can slip and fall over. Serious personal injury and damage to components can result.

Installation on Non-Prepped Axles

Sequence for Installing a Standard MTIS System and an MTIS System with a ThermALERT System

1. Install the axle air fitting.
2. Prepare the axle.
3. Install the stator.
4. Install the wheel-end components.
5. Follow the remaining sections in the manual for the air and electrical components.

Axle Air Fitting

1. Wear safe eye protection.
2. Park the vehicle on a level surface. Block the wheels to prevent the vehicle from moving.
3. On Meritor axles, locate the top-center of the axle, which is the preferred location for the axle air fitting. For other axle manufacturers, this location may vary. If the axle manufacturer has installed a top-center hole in the axle, use this hole as a pilot when you drill for the air fitting. Figure 2.1.

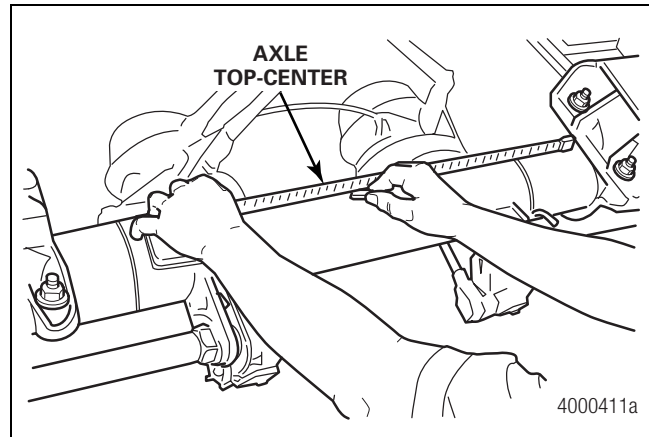

Figure 2.1

4. Use drilling lubricant and a variable speed electrical drill to drill an 11/32-inch diameter hole STRAIGHT into the top-center of the axle. Figure 2.2.

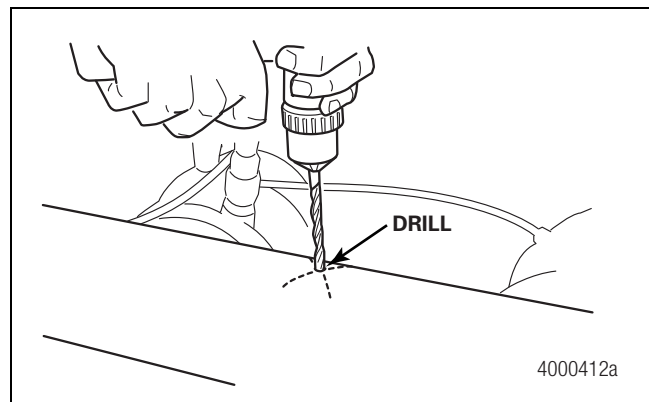

Figure 2.2

5. Use tapping fluid and a 1/8-27 inch NPT tap to thread the drilled hole STRAIGHT into the axle. Do not run the tap completely through the hole. Leave 1/4- to 3/8-inch of the tap threads exposed. Figure 2.3.

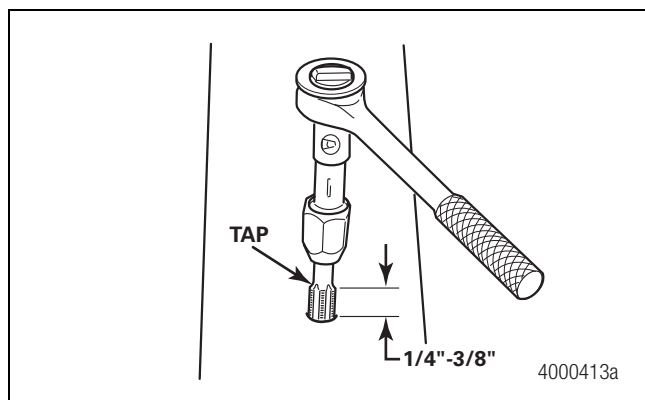

Figure 2.3

- Hand-tighten the axle air fitting into the tapped hole. Then use a wrench to tighten the fitting 2-1/2 additional turns to obtain an air tight seal. Continue to tighten until the fitting faces TOWARD the side of the trailer where you'll install the system control box. Figure 2.4. It is not necessary to apply a sealer when the axle air fitting is first installed if current production fittings have sealant pre-applied to the threads. If the part is removed, however, apply a sealant tape to the threads prior to reinstalling. Figure 2.5.

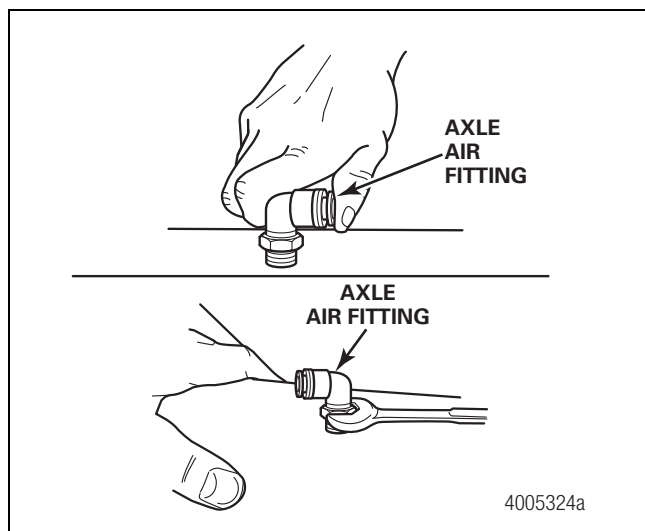

Figure 2.4

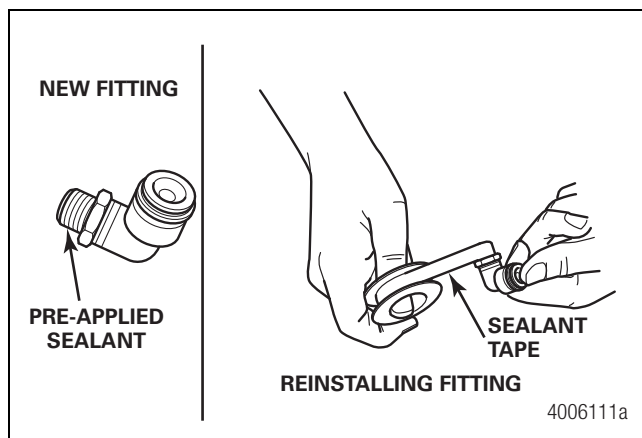

Figure 2.5

Prepare a Hollow Spindle Axle to Install the Standard MTIS and MTIS with the ThermALERT System

⚠ CAUTION

Cover the wheel ends at both ends of the axle during system installation to prevent contaminants from entering the wheel end. Damage to the bearings and seals can result.

- Wear safe eye protection.
- Park the vehicle on a level surface. Block the wheels to prevent the vehicle from moving.
- Place a container under the hubcap to receive the draining oil. Then, remove the hubcap and hubcap gasket from both ends of the axle. Figure 2.6. Do not reuse either the hubcap gasket or the oil.

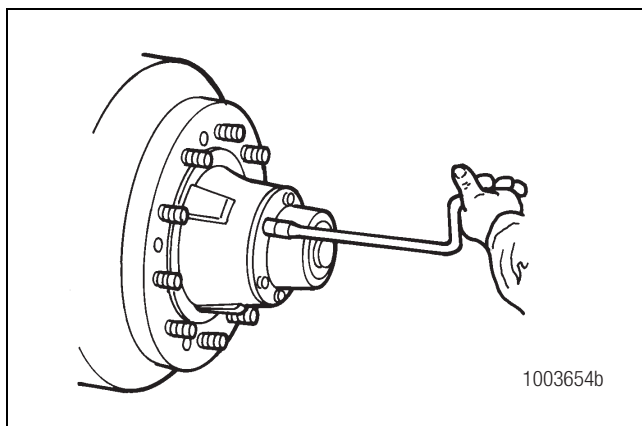

Figure 2.6

2 Assembly and Installation

4. Cover the wheel ends at both ends of the axle with a clean towel. Figure 2.7.

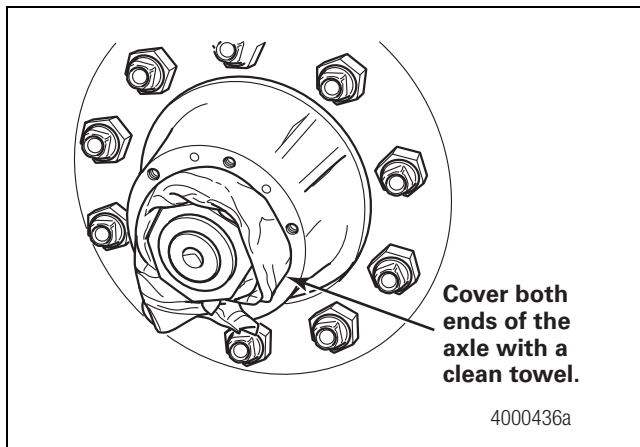

Figure 2.7

5. Use a slide hammer fitted with the welsh plug removal spear to remove the spindle welsh plugs from both ends of the axle. Use care not to score the inside diameter of the spindle bore. Figure 2.8. A slide hammer and welsh plug removal spear are available from Meritor to help remove these plugs. Refer to Section 7 for part numbers of special tools and supplies.

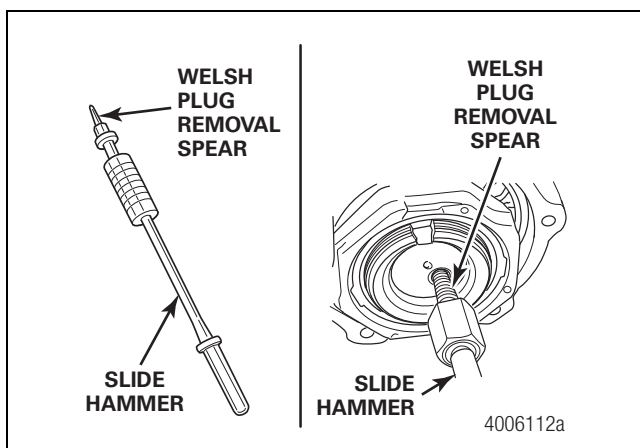

Figure 2.8

⚠ CAUTION

Use a bore polisher to remove all old adhesive from the spindle bore before you apply retaining compound to install the axle press plug. Retaining compound must contact a bare metal surface or it will not harden. Damage to components can result.

6. Choose the correct sized bore polisher by matching the axle manufacturer and model to the bore polishing tools listed in Section 7. Figure 2.9.

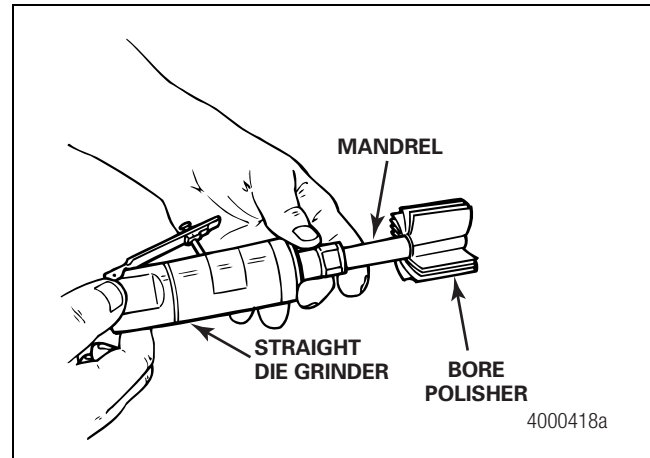

Figure 2.9

7. Polish the spindle bore to remove all adhesive residue left from the old spindle plug and any metal burrs or sharp edges from the spindle bore surface. Figure 2.10.
 - If the axle spindle is equipped with cotter pin holes: Use a round abrasive tool to remove all metal burrs and sharp edges from the spindle bore side of the cotter pin holes. Figure 2.11.

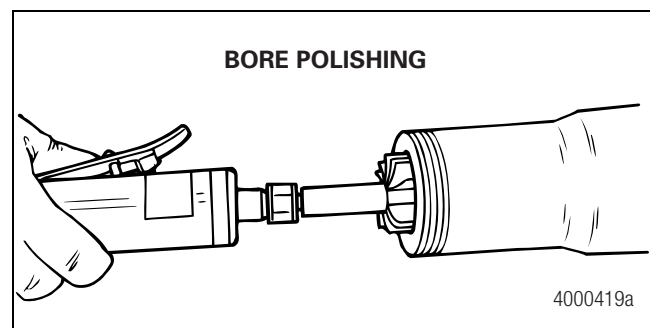

Figure 2.10

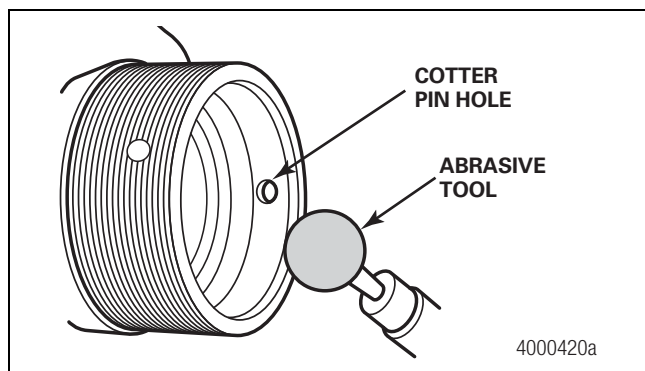

Figure 2.11

⚠ CAUTION

Use a cleaning wand and high-volume air to clean debris from the axle interior before you install the tire inflation system axle press plugs. Check that the axle is clear of debris, including loose rust, scale, liquid and machining residue. A contaminated axle can damage the tire inflation system and void the warranty.

8. Connect a cleaning wand to a high-volume air supply. Refer to Section 7 for information on building a cleaning wand. Figure 2.12. Slowly push the wand through the axle until it exits the opposite end. During this operation, a steady stream of air will be blowing from the axle spindle. Figure 2.13.

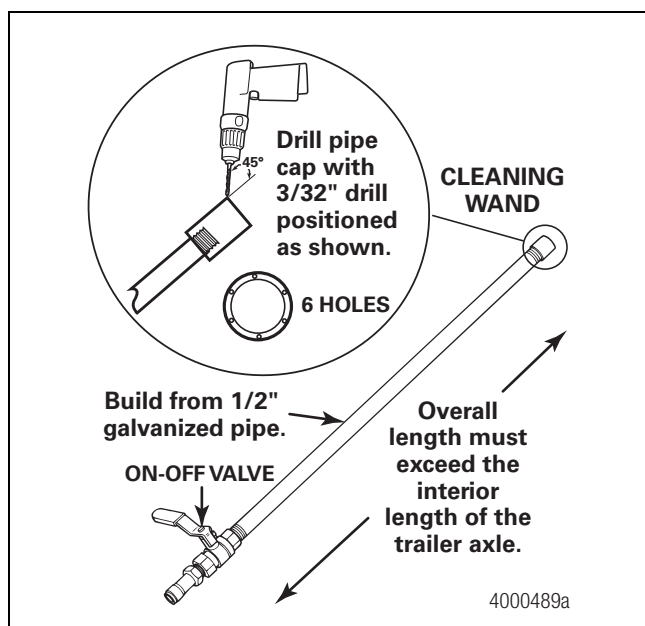

Figure 2.12

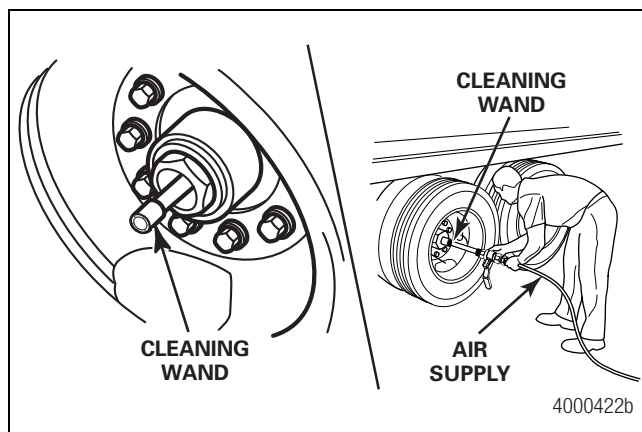

Figure 2.13

9. Check the inside of the axle tube with a flashlight by shining the light into one end of the spindle and looking through the opposite end. Confirm that all debris, including loose rust, scale, liquid and machining residue has been removed. Figure 2.14.

- **If necessary:** Repeat the cleaning procedure until the axle is clear of debris. For debris that's difficult to remove, it may be helpful to push the cleaning wand through the axle from the opposite end.

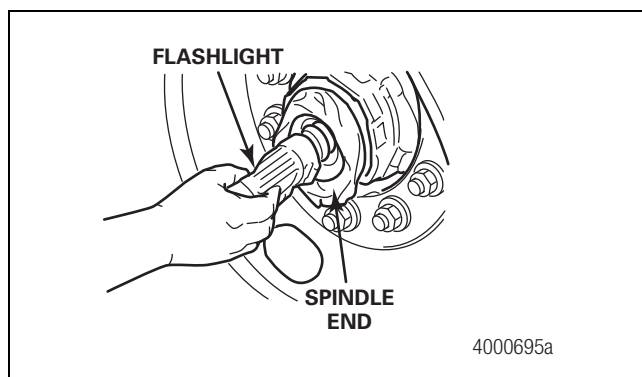

Figure 2.14

10. Choose the correct axle press plug drive adapter by matching the axle manufacturer and model to the axle press plug drive adapters. Refer to Section 7. Figure 2.15. Current production axle press plug drive adapters are identified with a number stamped on the part. Some early adapters were not marked.

2 Assembly and Installation

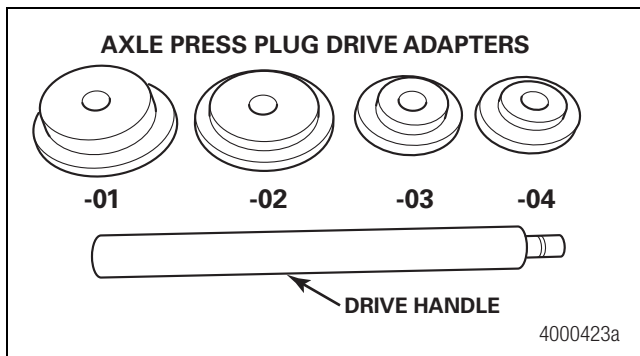

Figure 2.15

11. Install the axle press plug drive adapter onto the drive handle. Figure 2.16.

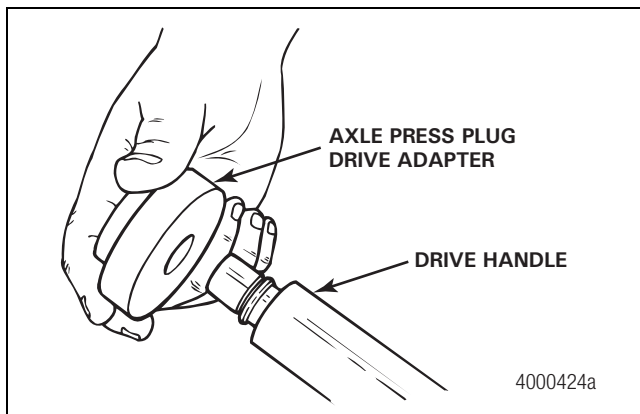

Figure 2.16

12. Clean the exposed O-ring surface and outside diameter surface of one axle press plug using a towelette provided in the installation kit. Use a new towelette for each wheel end. Protect the cleaned plug from additional contaminants. Figure 2.17.

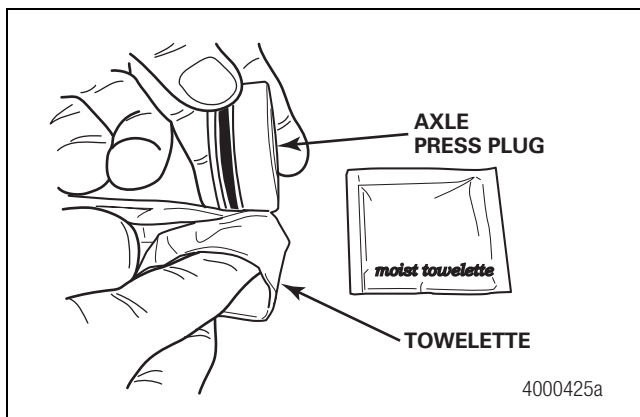

Figure 2.17

13. Use the same towelette to clean one spindle bore of contaminants such as grinding dust, dirt and wheel-end lubricant. Protect the cleaned bore from additional contaminants. Figure 2.18.

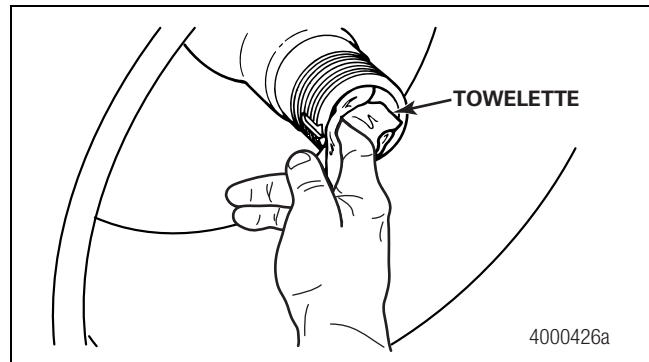

Figure 2.18

⚠ CAUTION

Only use the retaining compound supplied in the installation kit when you install the axle press plug. Only apply retaining compound to the **OUTSIDE** diameter of the axle press plug. Do not apply it to the inside diameter of the spindle bore, axle press plug stator threads or axle spindle threads. Damage to components can result.

14. Put on a new pair of latex gloves. Apply only the approved retaining compound included in the installation kit evenly to the **OUTSIDE** diameter of the axle press plug. The installation kit contains enough retaining compound for four wheel ends. Divide the material equally among the wheel ends. The axle press plug must be installed within 10 minutes of applying the retaining compound to ensure that the compound hardens correctly. Loctite® 620, 3M RT20 and PermaBond HH 0040 are all approved retaining compounds. Figure 2.19.

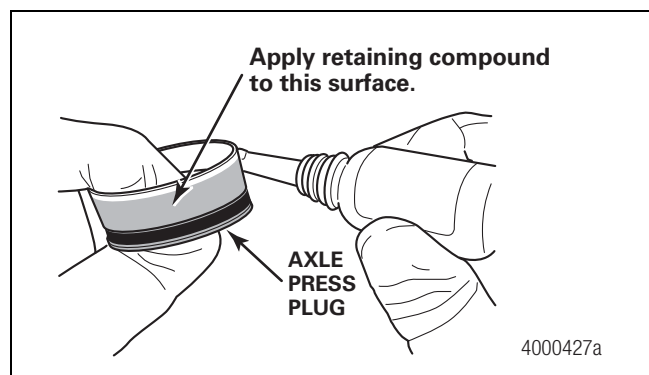

Figure 2.19

2 Assembly and Installation

15. If you are installing an axle press plug fitted with a thermal plug for a ThermALERT system, install the axle press plug with the thermal plug positioned at 12 o'clock (± 15 degrees). Figure 2.20.

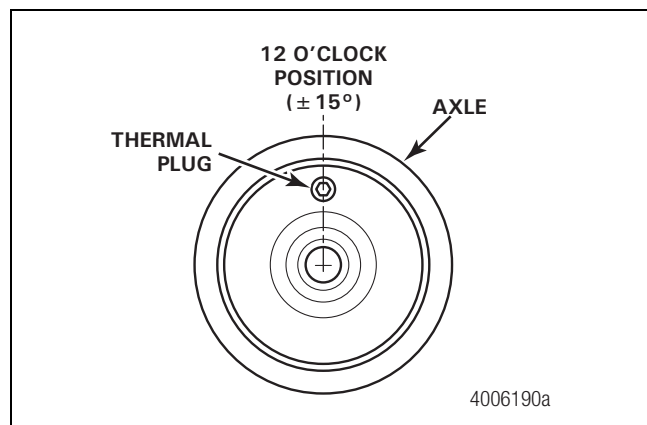

Figure 2.20

16. Insert the axle press plug into the spindle bore by hand until the plug stops in the bore. Figure 2.21.

- **For Holland Propar Axles Only:** The axle press plug slots must align with the spindle cotter pin holes. Figure 2.22.

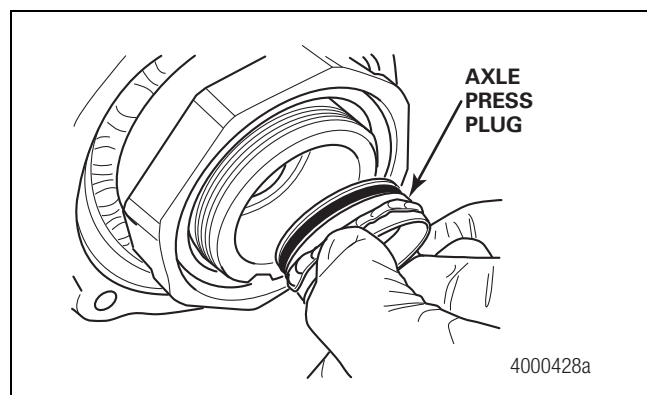

Figure 2.21

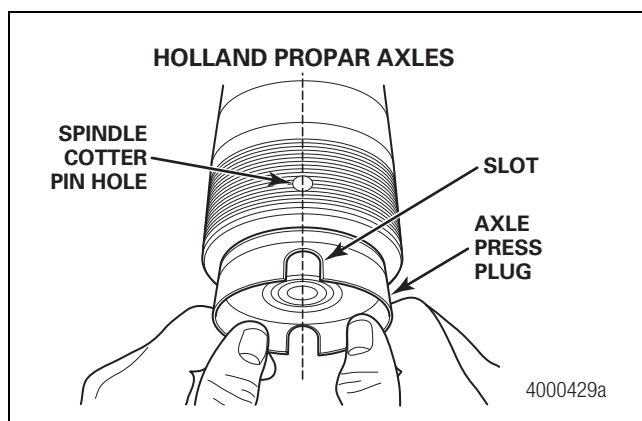

Figure 2.22

17. Check that the axle press plug protrudes from 1/8-1/4-inch (3.175-6.35 mm) from the end of the spindle. Figure 2.23.

- **If the axle press plug protrudes outside this acceptable range:** Before proceeding, contact the Meritor OnTrac™ Customer Call Center at 866-OnTrac1 (668-7221).
- **If the axle press plug is fitted with a thermal plug for a ThermALERT system:** Ensure that the thermal plug is located UP at the 12 o'clock (± 15 degrees) position when the axle is installed under the trailer. Figure 2.20.

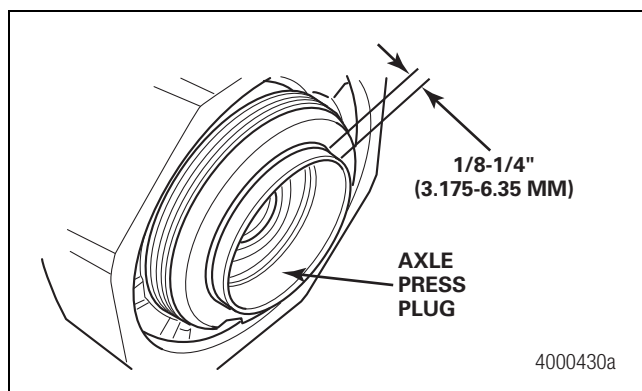

Figure 2.23

18. Insert the axle press plug drive adapter into the axle press plug. Figure 2.24.

2 Assembly and Installation

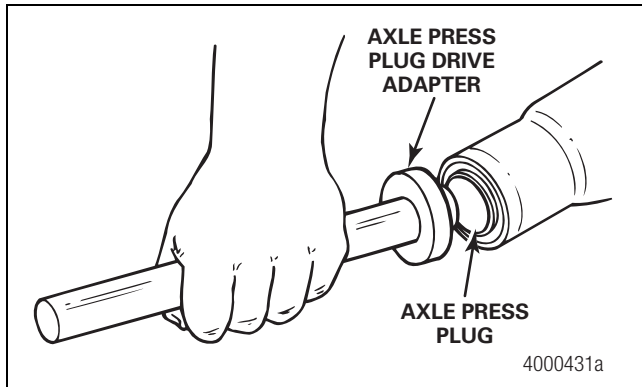

Figure 2.24

⚠ WARNING

Use a brass or synthetic mallet for assembly and disassembly procedures. Do not hit steel parts with a steel hammer. Pieces of a part can break off. Serious personal injury and damage to components can result.

⚠ CAUTION

The installed axle press plug must be seated square to the end of the spindle and inset at or below any chamfer in the axle spindle bore. An axle press plug that is flush with the end of the spindle is not seated correctly. Damage to components can result.

19. Use a four-pound brass or synthetic mallet to drive the axle press plug into the spindle bore, until the drive adapter bottoms out squarely on the end of the spindle. The drive adapter sets the axle press plug installation depth. There will be a definite change in the sound and feel of the hammering when the drive adapter bottoms out. The tire inflation system can be pressurized 30 minutes after installation of the axle press plug. Figure 2.25.

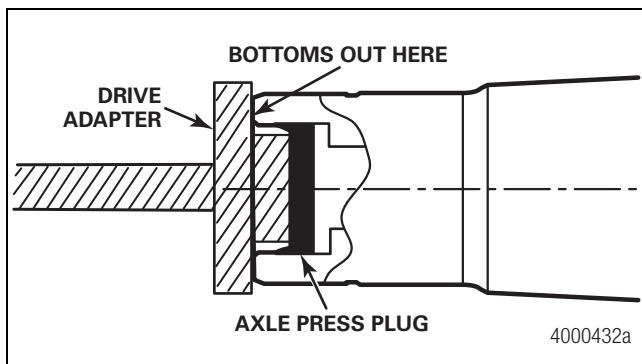

Figure 2.25

20. Wipe off all retaining compound residue from the spindle and axle press plug drive adapter. Figure 2.26.

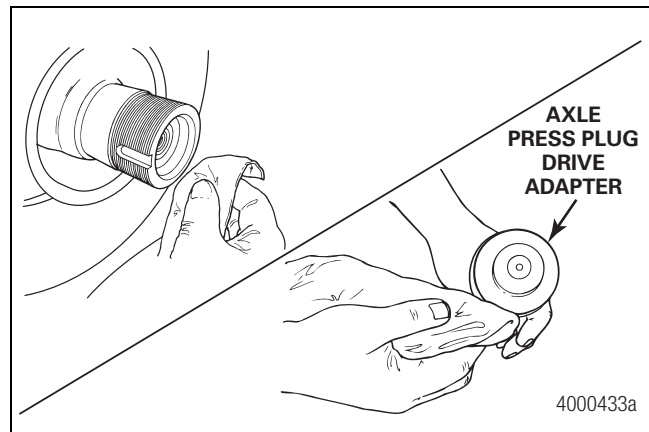

Figure 2.26

Prepare a Solid Spindle Axle to Install Standard MTIS Without the ThermALERT System

Important Note: The ThermALERT system cannot be installed onto a solid spindle axle.

Only use Meritor's drill jig (part number 81023-00) to drill a hole into a solid spindle axle to install the tire inflation system. Refer to the Service Notes page on the front inside cover of this manual to obtain the drill jig.

1. Wear safe eye protection.

⚠ CAUTION

Use only Meritor's solid spindle drill jig (part number 81023-00) to drill a hole into a solid spindle axle to install the tire inflation system. Meritor's drill jig helps to ensure that the hole will be concentric to the spindle end circumference. Do not drill a hole into the axle by hand. Do not use a drill jig from another manufacturer, or install the drill jig as an assembly. Damage to components can result.

2. Use a Meritor drill jig. Correctly support the Meritor drill jig with at least two full spindle threads. If necessary, remove the trailer axle outer spindle nut to expose at least two full threads. Figure 2.27.

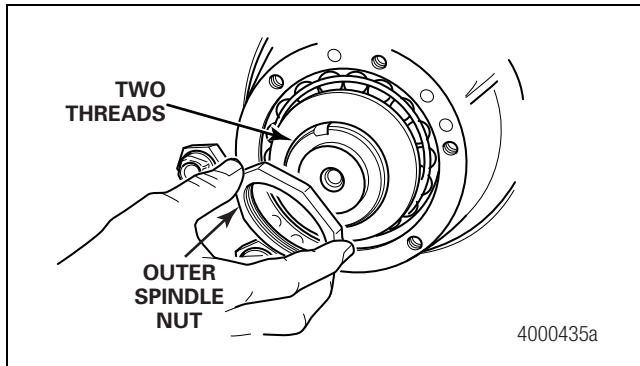

Figure 2.27

⚠ CAUTION

Cover the wheel ends at both ends of the axle during system installation to prevent contaminants from entering the wheel end. Damage to the bearings and seals can result.

3. Cover the wheel ends at both ends of the axle with a clean towel. Figure 2.28.

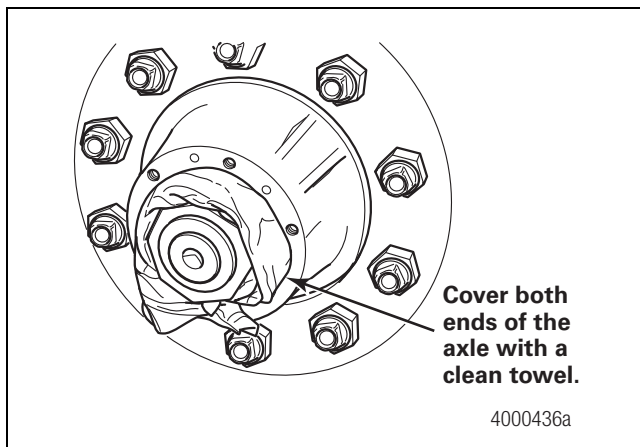

Figure 2.28

4. Clean the drill jig spindle installation nut and the axle spindle nut. This will allow the drill jig to be correctly concentric to the axle.
5. Install the 12 x 7/16-inch diameter drill bit into the drill. Figure 2.29.

2 Assembly and Installation

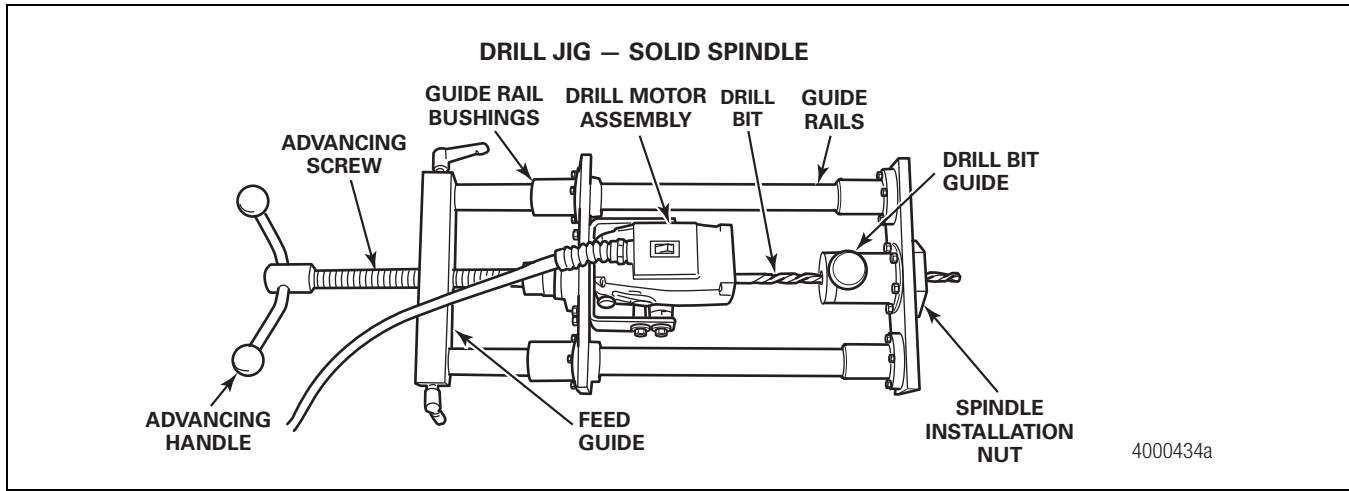

Figure 2.29

6. Thread the guide rails onto the axle spindle. Use a bar to tighten the rails. Figure 2.30.

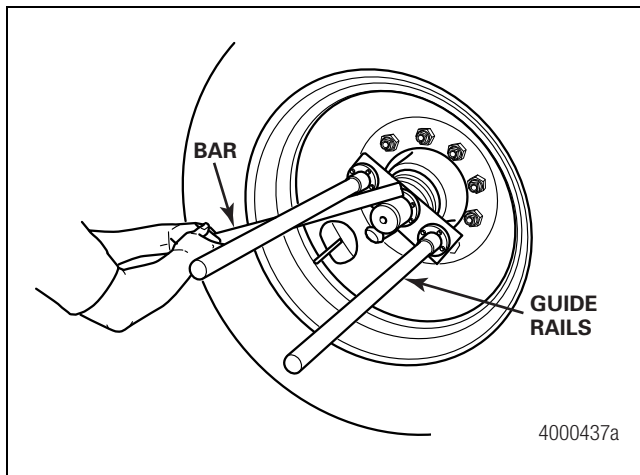

Figure 2.30

7. Slide the drill motor assembly onto the guide rails. Ensure that the drill bit is inserted into the drill bit guide. Figure 2.31 and Figure 2.32.

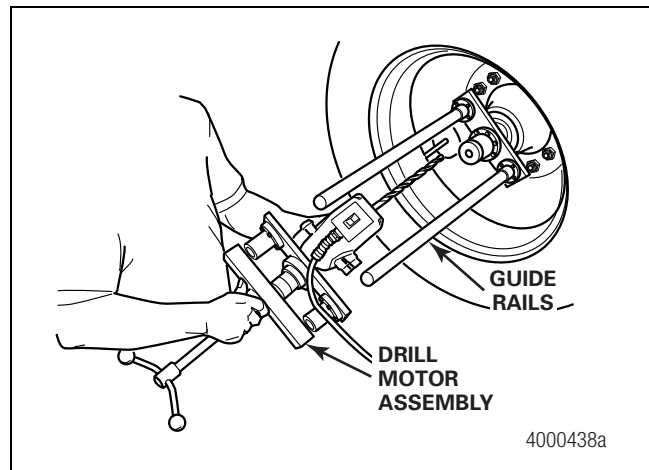

Figure 2.31

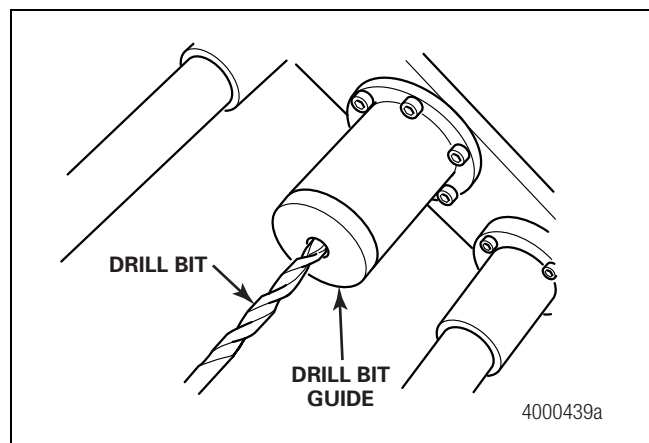

Figure 2.32

2 Assembly and Installation

8. Tighten the feed guide onto the guide rails. Figure 2.33.

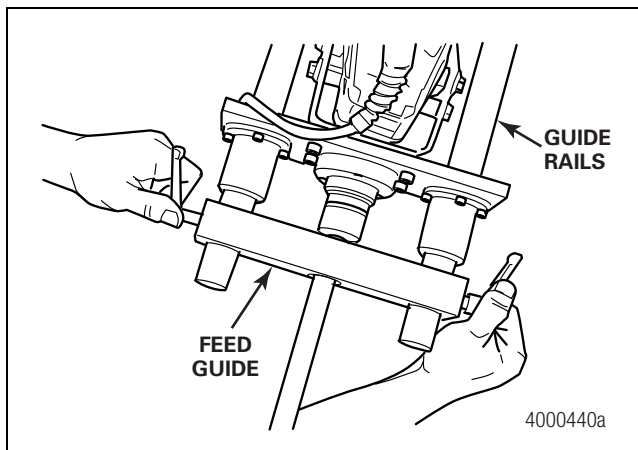

Figure 2.33

9. Turn the advancing handle CLOCKWISE until the drill bit bottoms out on the spindle. Then, back off the handle one full turn. Figure 2.34.

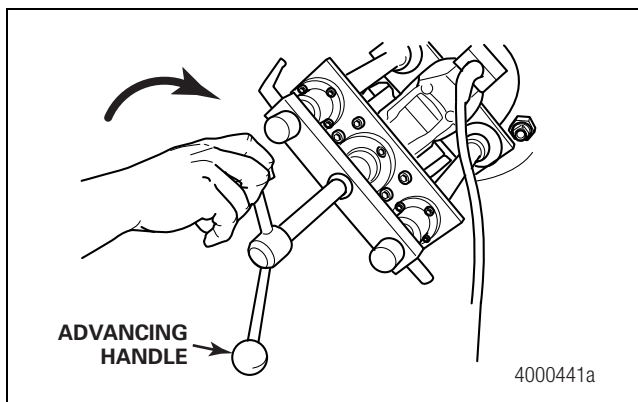

Figure 2.34

10. Turn the motor ON and drill into the spindle by slowly turning the advancing handle CLOCKWISE with a smooth, steady feed. Remove the drill bit guide periodically to remove metal shavings. No lubrication is needed during the drilling operation. Check that the guide rails are clean to ensure that the drill will advance smoothly. Figure 2.34 and Figure 2.35.

- **If the drill stalls or lags:** Back off the advancing handle COUNTERCLOCKWISE a few turns while the drill is on, then resume drilling. Figure 2.36.

- **When the drill bottoms out or breaks through the solid spindle:** Turn the advancing handle COUNTERCLOCKWISE a few turns while the drill is on. Release the feed guide and pull the drill out of the hole.
- **If the 12-inch drill bit does not break through:** Install the 18 x 7/16-inch drill bit. Use the same procedure to continue to drill until you break through the solid spindle.

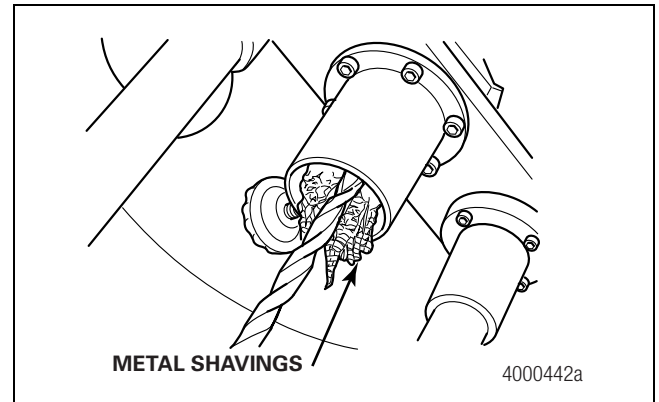

Figure 2.35

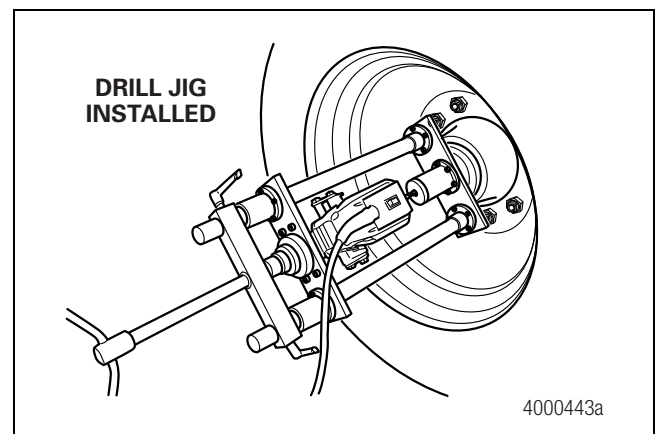

Figure 2.36

11. Remove all drill jig components from the spindle. Clean the axle end. Use shop air to clean the drilled hole. Figure 2.37.

2 Assembly and Installation

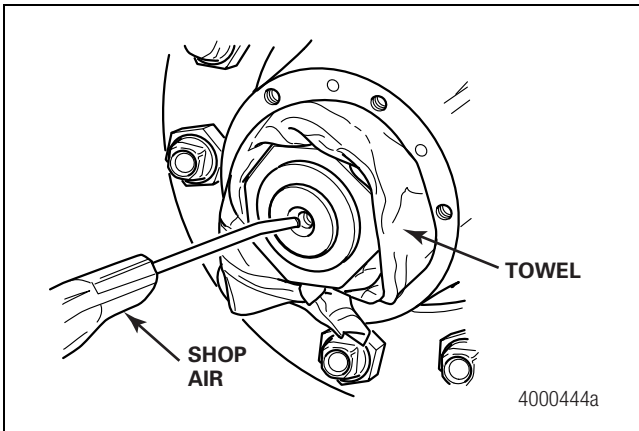

Figure 2.37

⚠ CAUTION

Always use a tap guide to tap the hole in the axle spindle. This will help to ensure that the threads are square to the spindle end and help prevent damage to components.

12. Install the tap guide onto the axle spindle. Tap the axle spindle with a 1/4-inch NPT tap. A 1/2-inch, 12-point socket and 3/8-inch drive ratchet can be used to drive the tap. Use tapping lubricant. Figure 2.38. Refer to Section 7 for the solid spindle tap guide part number.

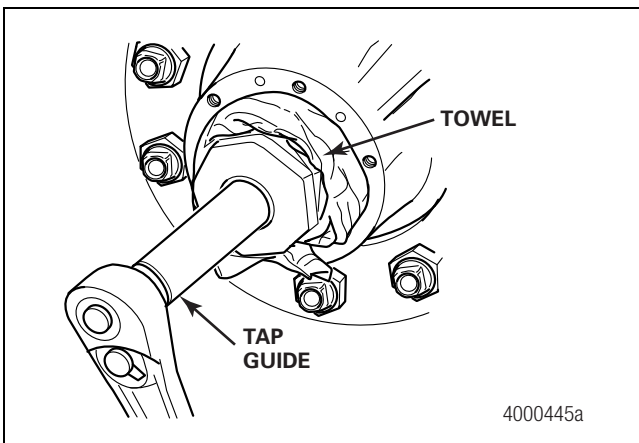

Figure 2.38

13. Remove the tap guide. Clean the axle end. Use shop air to clean the tapped hole. Figure 2.37.

- If the outer spindle nut was removed to install the drill jig: Reinstall the spindle nut using the axle manufacturer's instructions. Verify that the wheel end play is correct. For Meritor axles, refer to Maintenance Manual 14, Trailer Axles. To obtain this publication, refer to the Service Notes page on the front inside cover of this manual.

Stator

It is not necessary to apply a sealer when the stator is first installed if current production stators have sealant pre-applied to the threads. However, if the stator is removed, apply a thread sealant prior to reinstalling. Figure 2.39.

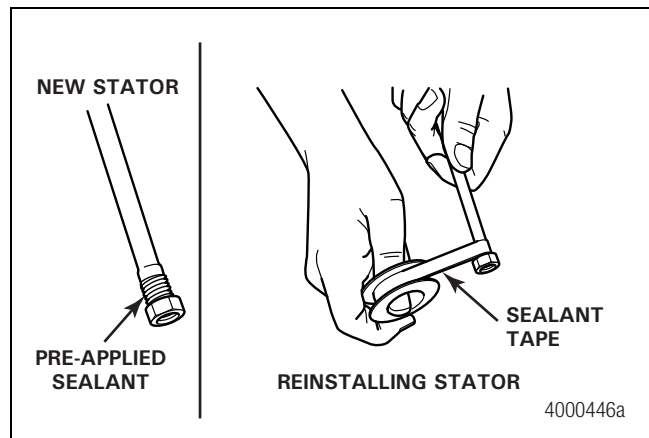

Figure 2.39

1. Hand-tighten the stator into the spindle hole. Figure 2.40.

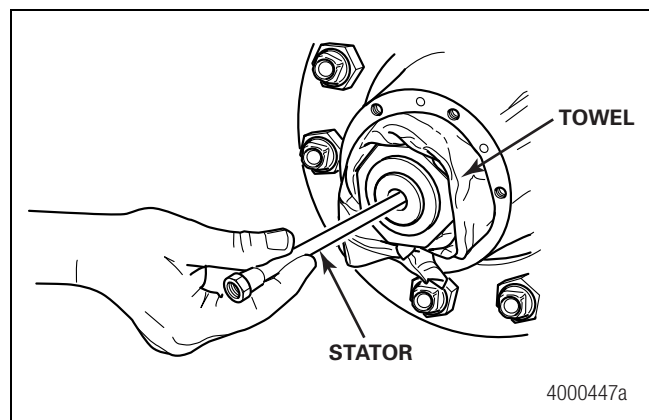



Figure 2.40

2. Use a 5/8-inch socket to tighten the stator approximately 2-1/2 additional turns, or 23-28 lb-ft (31.18-37.96 N•m), to obtain an airtight seal. Figure 2.41. 

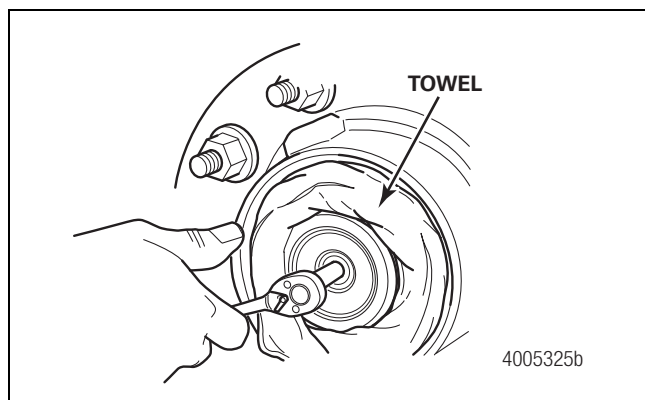

Figure 2.41

Wheel-End Components

Hubcaps are available in bolt-on or screw-on models, and models for grease or oil-lubricated wheel ends. All tire inflation system hubcaps include six vent holes designed to prevent pressure buildup in the wheel end.

Oil hubcaps typically feature a side-mounted oil fill plug and vent hole extensions located in the hubcap interior to keep oil from leaking from the hubcap vent holes. Figure 2.42 and Figure 2.43. Grease hubcaps also have six vent holes with vent extensions, however, they typically don't have a side-mounted fill plug. Figure 2.43.

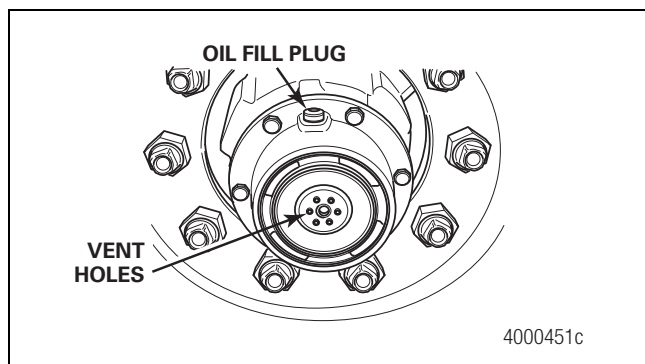

Figure 2.42

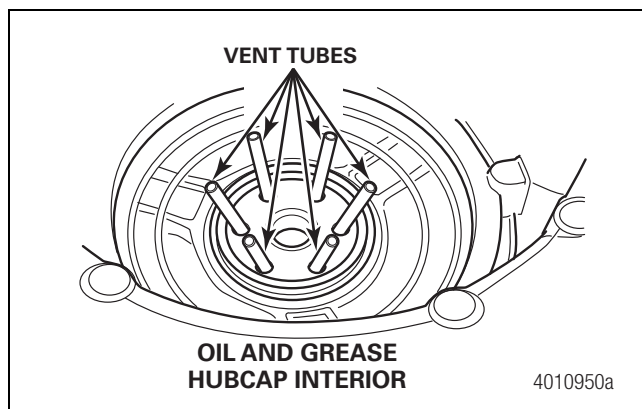

Figure 2.43

The thru-tee assembly consists of the tube, tee relief valve, deflector shield and tee. Figure 2.44.

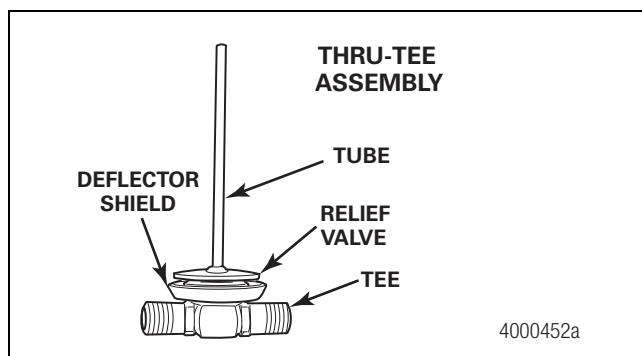

Figure 2.44

⚠ WARNING

Verify that the vent tube holes in a greased wheel end are not blocked with grease. Blocked vent tube holes will prevent system air from venting from the wheel end. Serious personal injury and damage to components can result.

1. Follow the manufacturer's instructions to install the hubcap. For oil-lubricated wheel ends, locate the oil fill plug on the top. Verify that the vent holes in a greased wheel end are not blocked with grease. Blocked vent tube holes will prevent system air from venting from the wheel end. Figure 2.42.
2. Ensure the correct length tube is assembled to the thru-tee. Refer to Table A for the correct length. Figure 2.45.

2 Assembly and Installation

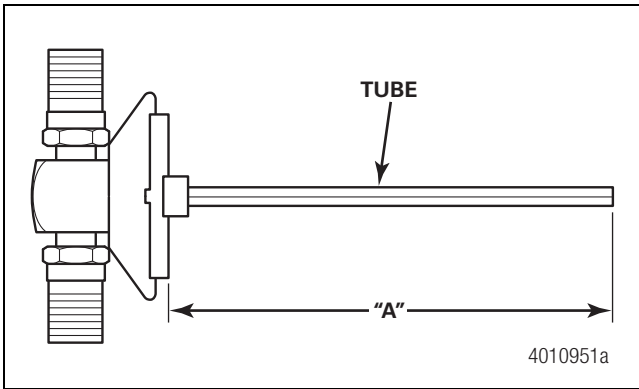

Figure 2.45

Table A: Thru-Tee Tube Length

Axle/ Spindle Type	Hub Type	"A" Thru-Tee Tube Length
TN/TQ, HN	Ductile Iron	3.5" (88.9 mm)
TN/TQ, HN	Aluminum	4" (101.6 mm)
TP, WP, HP (2.75" [69.85 mm] Bore)	Ductile Iron	4" (101.6 mm)
TP, WP, HP (2.75" [69.85 mm] Bore)	Aluminum	5" (127 mm)
TN/TQ or TP	PreSet or PreSet Plus	5" (127 mm)

- Use your fingers to check that there is no debris on the tube. Figure 2.46.

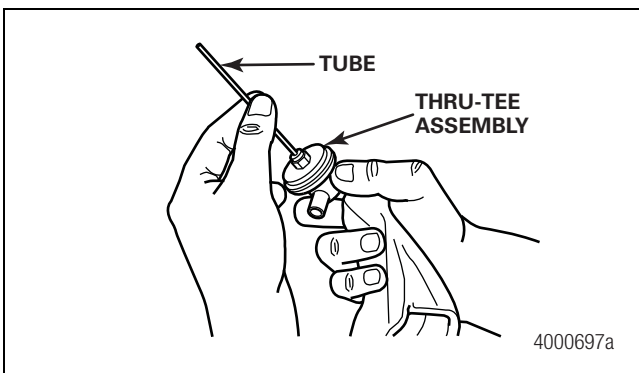

Figure 2.46

- Carefully install the thru-tee assembly STRAIGHT into the hubcap to insert the tube into the stator. When you insert the tube into the stator, it's normal to feel some resistance when the tube contacts the stator seal. Figure 2.47.

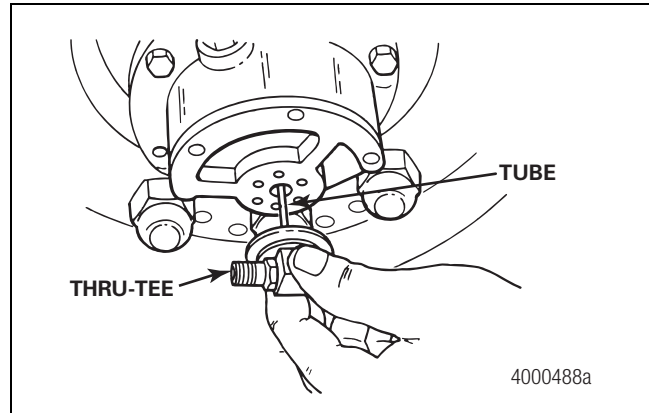



Figure 2.47

⚠ CAUTION

Do not overtighten the thru-tee assembly during installation. Damage to the component threads can result.

- Hand-tighten the thru-tee assembly. Tighten the tee with a torque wrench set at 45 lb-in (5 N•m). Check alignment of the tee air fittings to the tire valve stems. If aligned, go to Step 6. If not aligned, retighten the tee with a torque wrench set to 55 lb-in (6 N•m) and tighten until aligned. Do not exceed 55 lb-in (6 N•m). If still not aligned, repeat Step 5. Figure 2.48. 

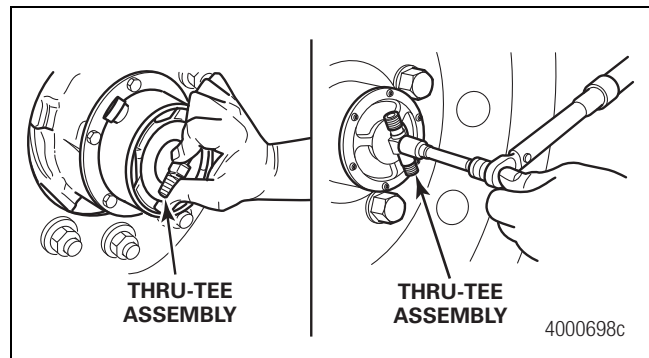

Figure 2.48

- The air fittings must point TOWARD the tire valve stems. Check that the tire valve stems are 180 degrees opposite each other. The valve stems must be in this position to install the tire inflation system. Figure 2.49. If necessary, bolt-on hubcaps or wheels may be “clocked” to align the thru-tee with the tire valve stems. Screw-on hubcaps may be rotated for this alignment, as long as the hubcap tightening specification is within the hubcap manufacturer’s recommended guidelines.

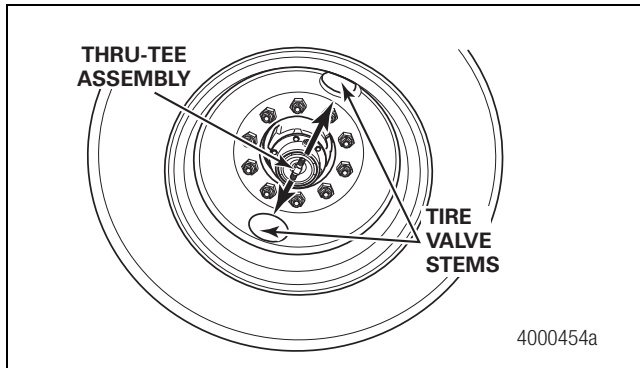

Figure 2.49

⚠ CAUTION

During installation, hand-tighten the tire inflation system hoses to the tire valve stems, then use a wrench to tighten the hoses to the correct specification. Do not overtighten the connection, this may damage the hose seal and cause a tire to deflate when the trailer is parked. Damage to components can result.

- Hand-tighten the tire inflation system hoses to the tire valve stems. Then use a 7/16-inch wrench to tighten the connections an additional half-turn. Figure 2.50.

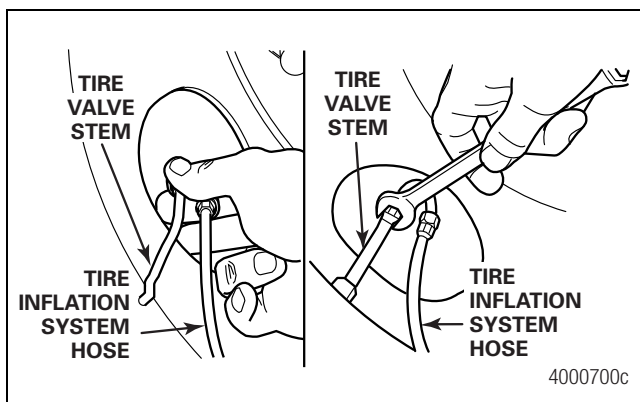

Figure 2.50

Air Components

Control Box

⚠ WARNING

A standard MTIS can have a control box with either a black flow sensing switch or a grey flow sensing switch. Both control boxes mount to the trailer in the same way. However, MTIS equipped with a ThermALERT system must have a control box with a grey flow sensing switch, which is more sensitive to air flow than the black switch.

If a ThermALERT system has a control box with a black flow sensing switch, replace it with a control box that has a grey switch. Otherwise, the warning light may not come ON if a wheel end overheats. Serious personal injury and damage to components can result.

It is important to note that there are two different control boxes. One is for the standard MTIS, and the other is for the MTIS with the ThermALERT system.

The control box for the standard MTIS can include a flow sensing switch that is either black or grey. The control box for the MTIS with the ThermALERT system must include a grey flow sensing switch. Both control boxes mount to the trailer in the same way.

The preferable location to install the tire inflation system control box is the ROADSIDE REAR of the subframe facing the REAR of the trailer. Mount the control box in a location that's accessible, free of hazards and positioned so the control box door can be opened.

Use the following procedure to mount the control box either to the supplied mounting bracket or directly to the trailer subframe. Check to ensure that the control box, electrical lines or air lines do not interfere with any suspension components in the system.

2 Assembly and Installation

Mounting Bracket Installation

⚠ WARNING

Axle weld locations and welding procedures must adhere to Meritor standards. Welding at locations other than those authorized by Meritor will void the warranty and can reduce component fatigue life. Serious personal injury and damage to components can result.

Wear safe clothing and eye protection when you use welding equipment. Welding equipment can burn you and cause serious personal injury. Follow the operating instructions and safety procedures recommended by the welding equipment manufacturers.

You can either weld or bolt the supplied mounting bracket to the trailer subframe.

1. Wear safe eye protection.
2. Park the vehicle on a level surface. Block the wheels to prevent the vehicle from moving.
3. Install the mounting bracket to position the control box as described in this section. Use one of the following installation procedures.
 - Weld the bracket to the subframe.
 - Use the supplied mounting bracket as a template and drill two 5/16-inch (0.80 cm) holes into the trailer subframe. Use the supplied fasteners, washers and locknuts to secure the bracket to the subframe. Figure 2.51 and Figure 2.52.

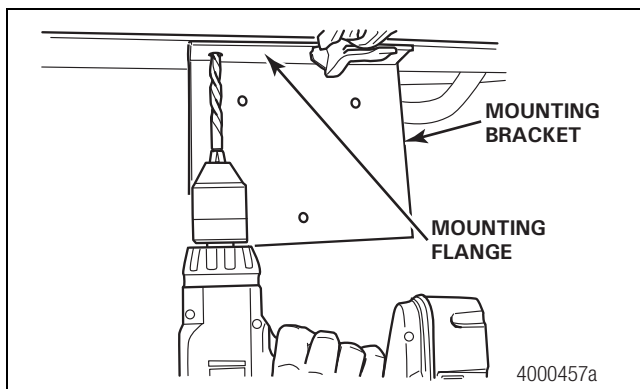

Figure 2.51

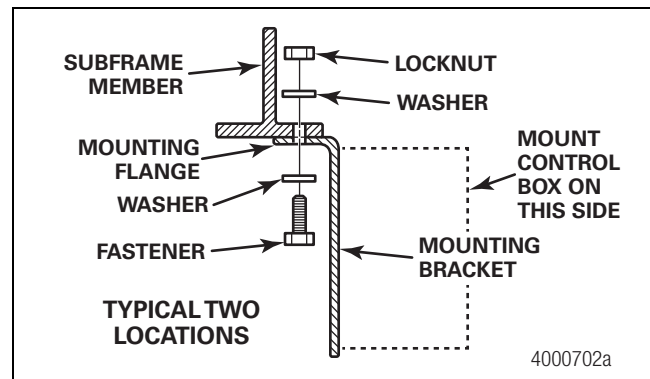

Figure 2.52

4. Install the control box to the mounting bracket opposite side of the mounting flange using the supplied 1/4-inch (6.36 mm) fasteners, washers and locknuts. Figure 2.52 and Figure 2.53.

NOTE: The bracket mounting flange must make complete contact with the surface area it is mounted on.

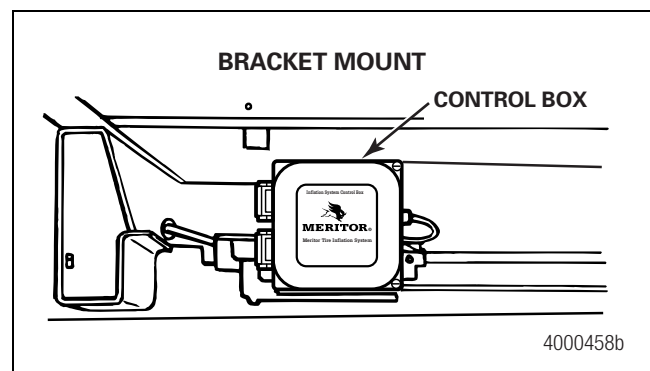

Figure 2.53

Trailer Subframe Installation

1. Locate the control box as described in this section. Use the supplied mounting bracket as a template and drill three 1/4-inch (6.36 mm) holes into an appropriate mounting surface to position the control box as described in this section. Figure 2.54.

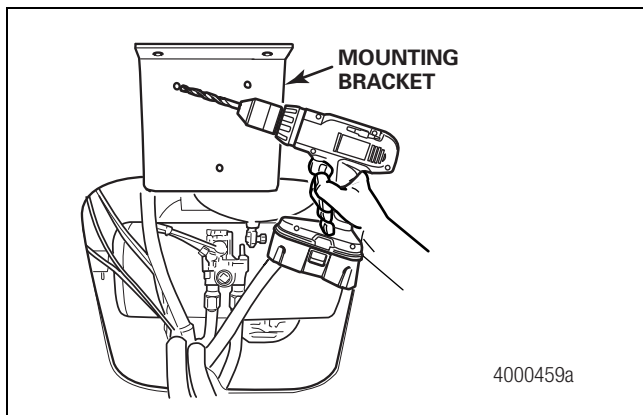

Figure 2.54

- Discard the supplied mounting bracket. Use the supplied 1/4-inch (6.36 mm) fasteners, washers and locknuts to install the control box directly to the subframe. Figure 2.55 and Figure 2.56.

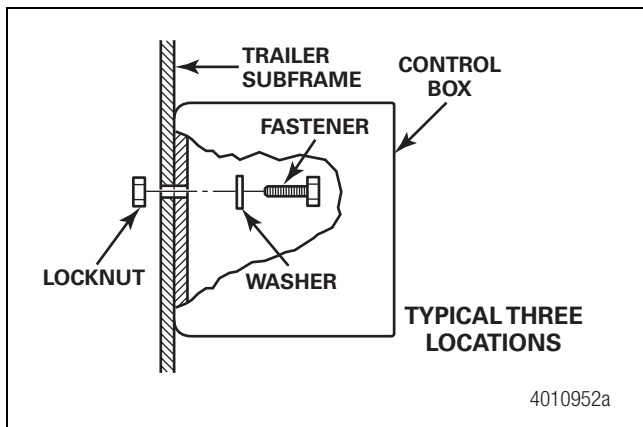

Figure 2.55

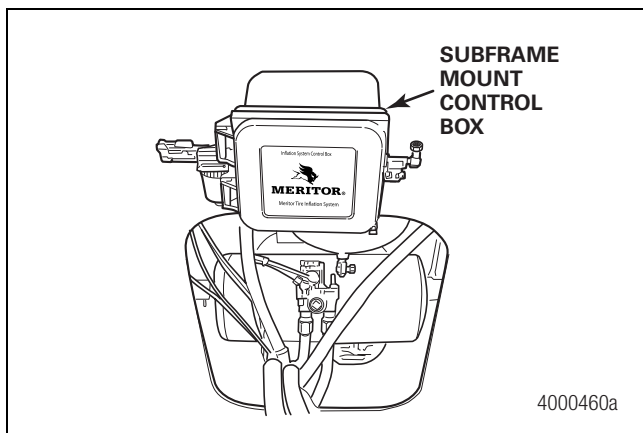

Figure 2.56

Pressure Protection Valve (PPV)

⚠ CAUTION

Check the wheel ends to ensure the tire inflation system valve stems and hoses do not contact the wheels or brake drums. Damage to components can result.

It is not necessary to apply a sealer when the PPV and installation nipple are first installed if the current production components have sealant pre-applied to the threads. However, if the PPV is removed, apply thread sealant prior to reinstalling. Figure 2.57.

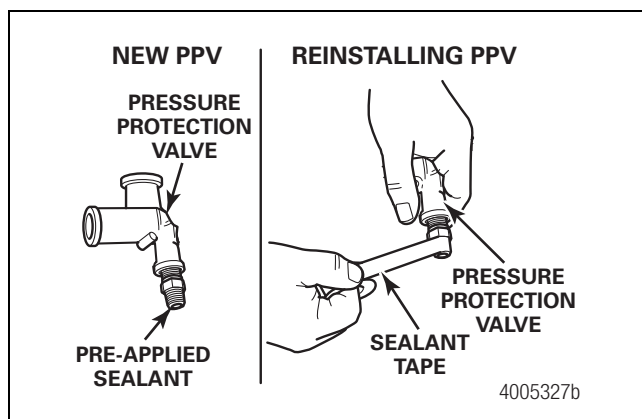

Figure 2.57

- Drain the air from the trailer air system service tank.
- Hand-tighten the installation nipple into a spare port in the air tank, preferably in the top half of the air tank. Then use an 11/16-inch wrench to tighten the nipple approximately two additional turns to obtain an airtight seal.
- Hand-tighten the PPV into the installation nipple. Use a wrench to tighten the PPV approximately two additional turns to obtain an airtight seal. When correctly installed, the slotted screw in the PPV should face DOWN. Figure 2.58.

2 Assembly and Installation

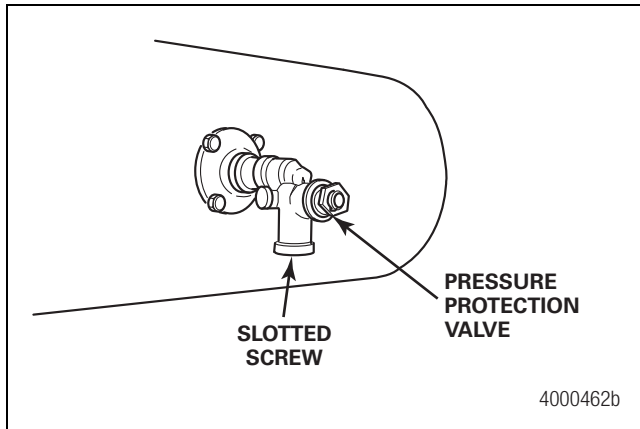

Figure 2.58

Air Lines

When you route the tire inflation system air lines, use grommets to protect them from contacting sharp edges at hole locations. Use tie wraps to secure them to the existing trailer brake air lines.

1. Route an air line from the PPV to the control box inlet port. Figure 2.59 and Figure 2.60. Hand-tighten the air line fittings, then use a 9/16-inch wrench to tighten them approximately one additional turn to obtain an airtight seal.

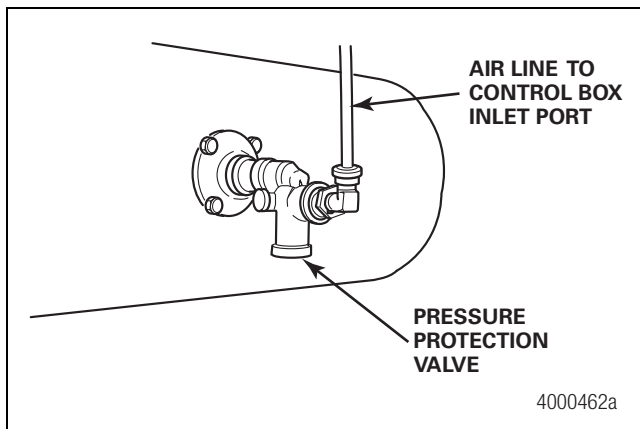

Figure 2.59

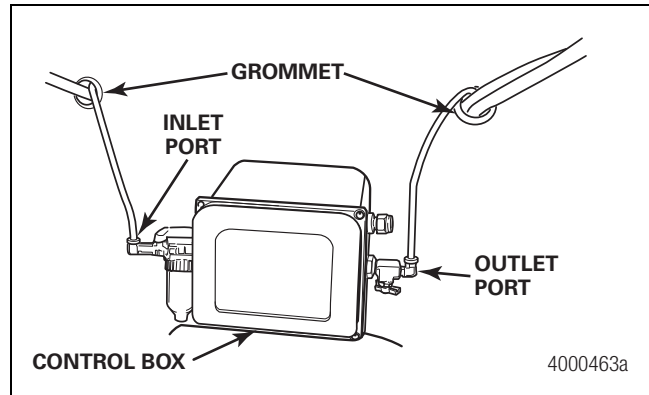

Figure 2.60

2. Route an air line from the control box outlet port to the air line tee. Suspend the tee AWAY from the trailer brake lines to protect these lines from damage. Figure 2.61. Hand-tighten the air line fittings, then use a 9/16-inch wrench to tighten them approximately one additional turn to obtain an airtight seal.

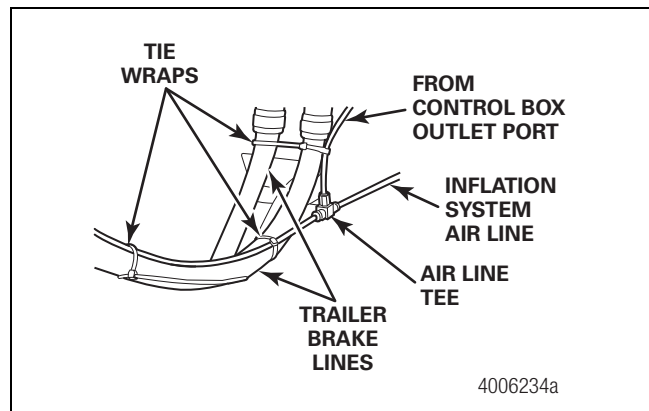

Figure 2.61

3. Route the air lines from the tee to the axle air fittings. Provide sufficient slack in the lines to allow for suspension movement. Use the slack in the existing trailer brake lines as a guide. Figure 2.62. Hand-tighten the air line fittings, then use a 9/16-inch wrench to tighten them approximately one additional turn to obtain an airtight seal.

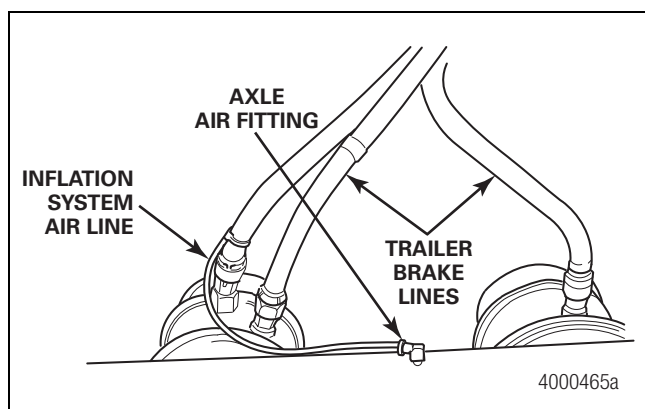

Figure 2.62

Electrical Components

⚠ WARNING

When working on an electrical system, the possibility of electrical shock exists, and sparks can ignite flammable substances. Always disconnect the battery ground cable before working on an electrical system to prevent serious personal injury and damage to components.

Standard Connection of Seven-Way Box

1. Disconnect the trailer's electric system from the tractor prior to working on the trailer's electrical system.
2. Connect the warning light to the wiring harness. The standard wire harness is shipped as a single assembly consisting of a black and white wire with spade terminals on one end that connect to the control box, and bullet terminals that connect to the warning light. Figure 2.63.

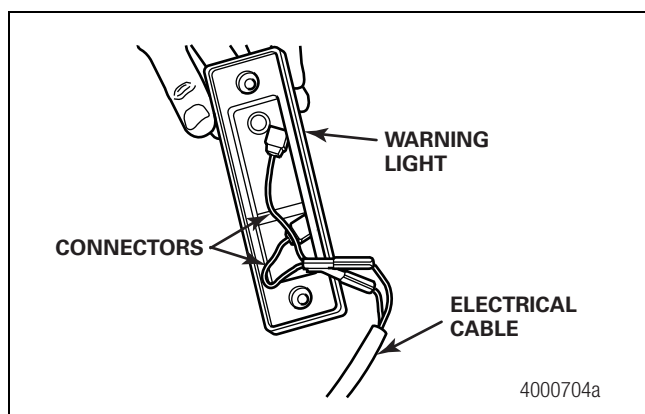

Figure 2.63

3. Mount the warning light vertically onto the roadside front of the trailer, approximately 30-inches (76 cm) from the bottom of the coupler and as close as possible to the outside of the trailer. The driver should be able to see the warning light from the roadside rear view mirror. Figure 2.64.

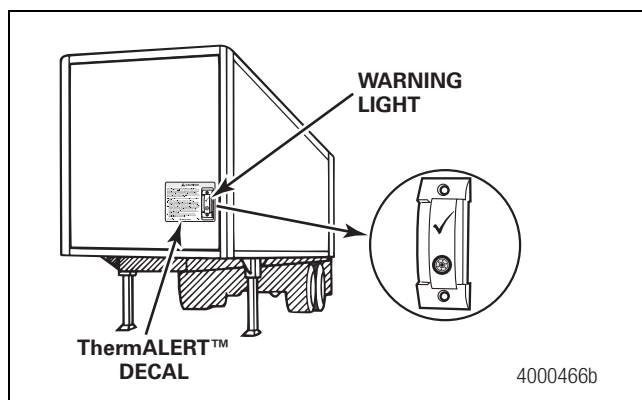

Figure 2.64

4. Route the wiring harness from the warning light to the trailer seven-way box. Secure the harness to the front of the trailer using the supplied P-clamps. Cut the harness ensuring there is sufficient length to make the connections in the seven-way box. Route the harness into the seven-way box. Figure 2.65.

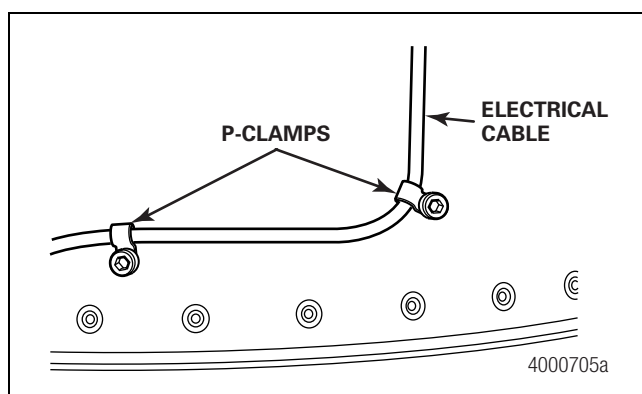

Figure 2.65

5. Route the remaining wire harness through the liquid tight seal on the control box and connect the harness to the electrical contacts of the flow sensing switch. The black or white wire can be connected to either terminal on the flow switch and are interchangeable. Figure 2.66.

2 Assembly and Installation

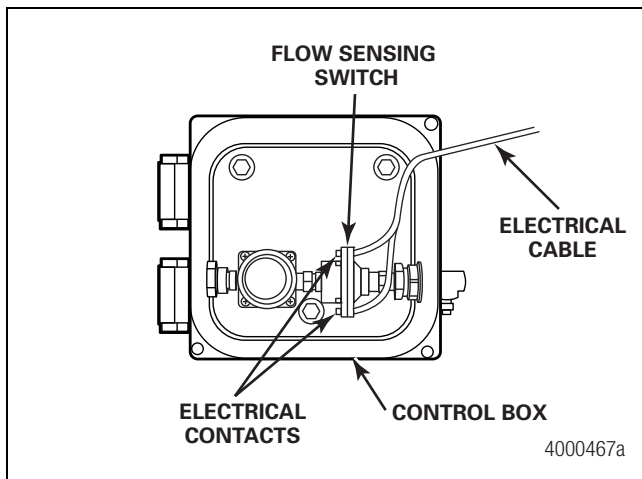

Figure 2.66

6. Route the wiring harness from the control box to the seven-way box. When you route the harness, use grommets to protect it from contacting sharp edges and use tie wraps to secure the harness.

- **If the trailer is equipped with a sliding subframe:**

Provide sufficient slack in the harness to allow for suspension movement. Use the slack in the existing trailer brake lines and electrical lines as a guide.

7. Route the harness into the seven-way box and remove any excess cable.
8. In the trailer seven-way box, connect the supplied eye connectors to the white wires, one coming from the warning light and one coming from the control box. Figure 2.67.

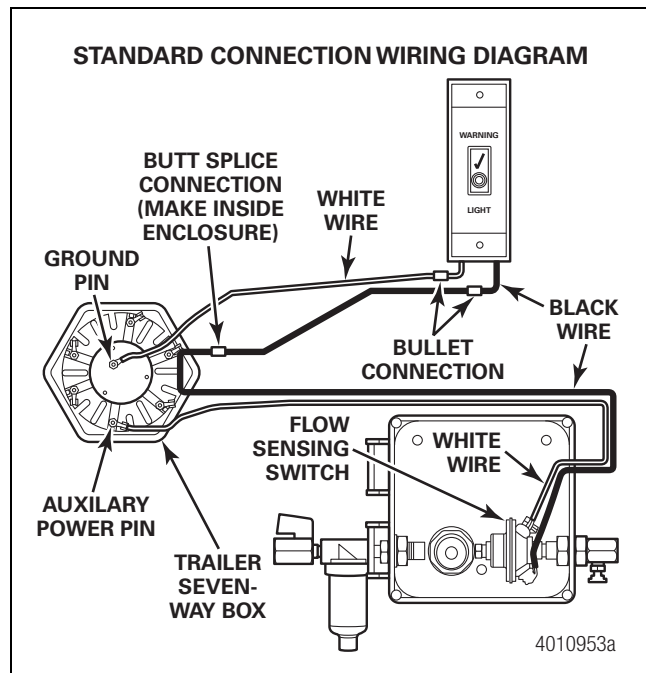

Figure 2.67

9. In the trailer seven-way box, connect the white wire eye connector from the control box to a pin that will supply constant power. Connect the white wire from the light to the ground. Figure 2.68.

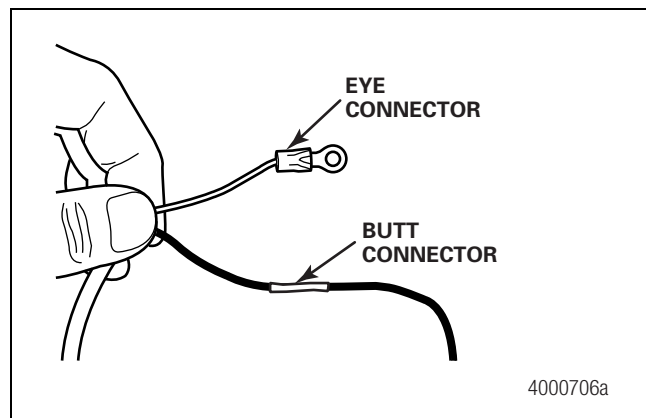

Figure 2.68

10. In the trailer seven-way box, use the supplied butt connector to connect the black wire from the warning light to the black wire from the control box.
11. If necessary, reconnect the trailer to the tractor's electrical system.

Optional Installation 1 — ABS Connection Inside Box

1. Mount the warning light.
2. Route the electrical cable from the warning light to the control box.
3. Route the ABS connector electrical cable to the control box.
4. Connect the blue wire from the ABS connector to the flow sensing switch. Connect the black wire from the warning light to the flow sensing switch. Connect the white wire from the warning light to the white wire from the ABS connector.

Figure 2.69.

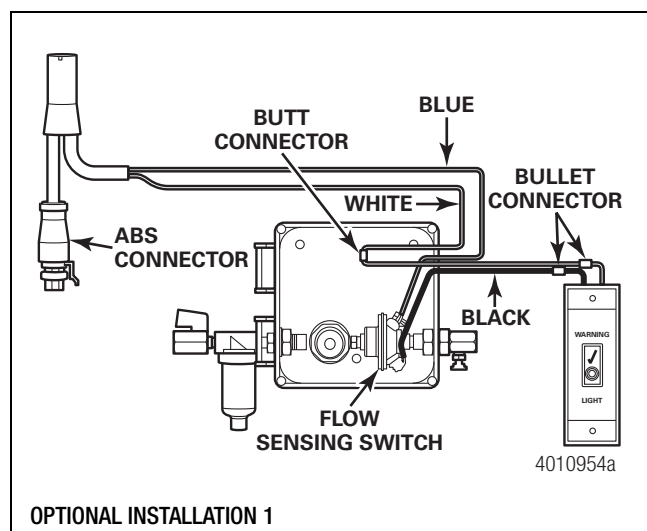

Figure 2.69

Optional Installation 2 — ABS Connection Outside Box

1. Mount the warning light.
2. Route a length of electrical cable from the warning light to the ABS connector.
3. Route the electrical cable from the control box to the ABS connector. Connect the electrical cable to the electrical contacts of the flow sensing switch.
4. At the ABS connector, connect the white wire from the control box to the blue wire from the ABS connector. Connect the black wire from the control box to the black wire from the warning light. Connect the white wire from the warning light to the white wire from the ABS connector. Use a liquid tight connector at all connections. Figure 2.70.

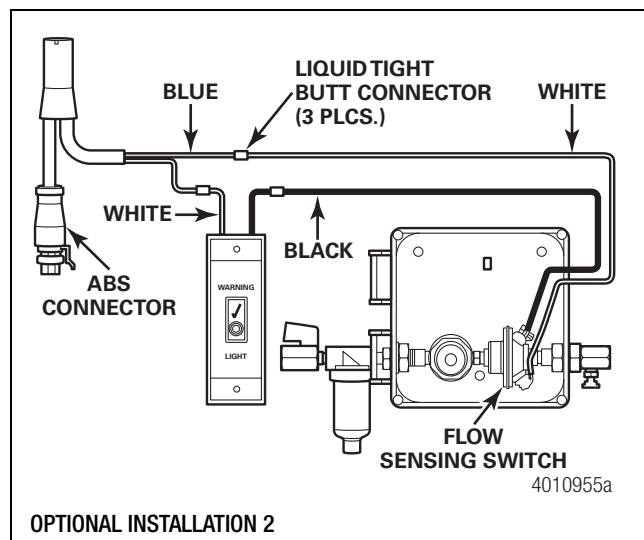

Figure 2.70

Wheel-End Oil

Refer to the trailer axle manufacturer literature for service instructions. For Meritor trailer axles, refer to Maintenance Manual 14, Trailer Axles. To obtain this publication, refer to the Service Notes page on the front inside cover of this manual.

If the wheel end is oil-lubricated, add oil through the hubcap fill plug to the manufacturer's recommended level. The oil level must be below the level of the six hubcap wheel-end vents. Figure 2.71 and Figure 2.72.

⚠ CAUTION

Do not overfill the wheel end with oil or damage to components may result.

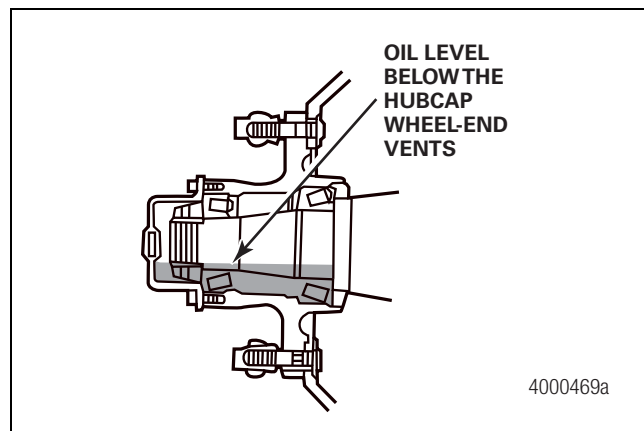

Figure 2.71

2 Assembly and Installation

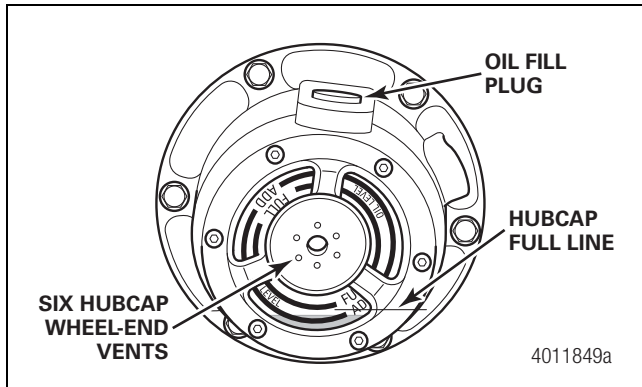

Figure 2.72

NOTE: ThermALERT became a standard feature in all MTIS kits starting October 1, 2017.

Standard MTIS and ThermALERT System Decals

Identification and information decals are used with the tire inflation system.

1. Install an identification and hose installation decal on each side of the trailer above the suspension. Figure 2.73.

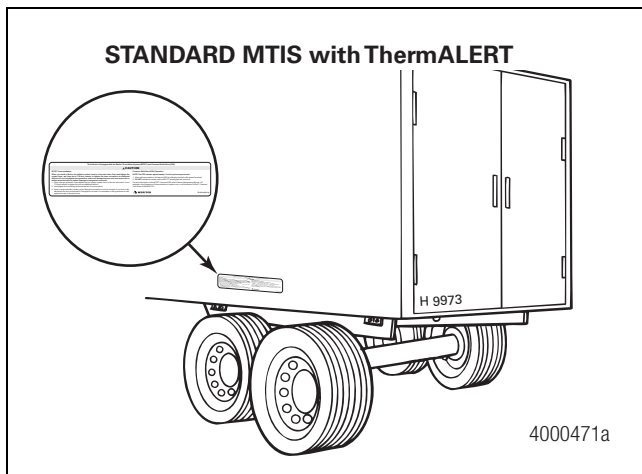

Figure 2.73

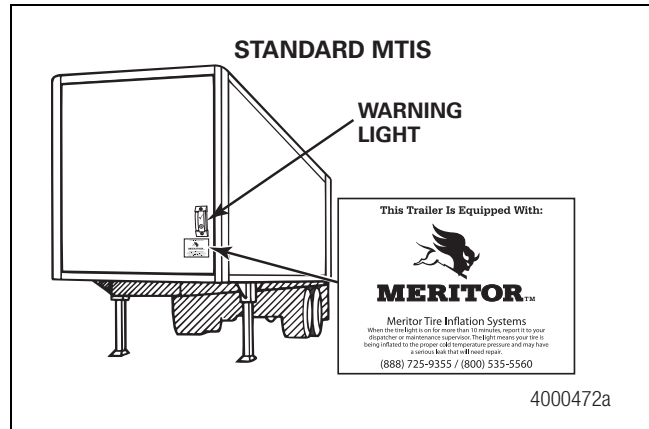

Figure 2.74

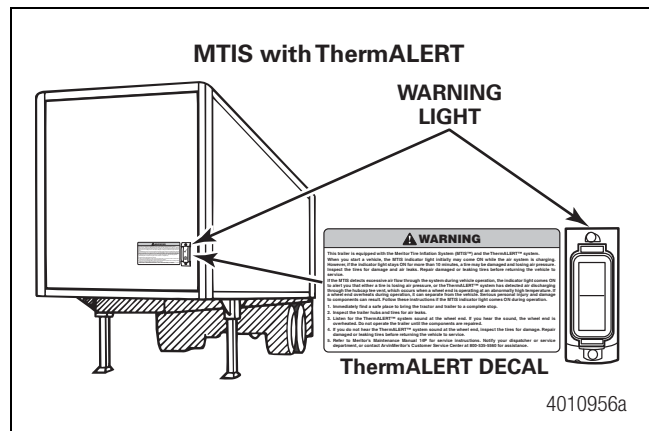

Figure 2.75

2. Install the warning light decal near the light. Figure 2.74 or Figure 2.75.

Hazard Alert Messages

Read and observe all Warning and Caution hazard alert messages in this publication. They provide information that can help prevent serious personal injury, damage to components, or both.

⚠ WARNING

To prevent serious eye injury, always wear safe eye protection when you perform vehicle maintenance or service.

Check System Operation

Use the following procedure to check the tire inflation system for correct operation. This inspection ensures that the system is activated, the warning light works, the hoses are installed correctly and that the system delivers the correct pressure to the tires.

1. Wear safe eye protection.
2. Check that the system ball valve is open. When the valve is open, the knob aligns with the valve body. Also, check that the drain petcock is closed. Figure 3.1.

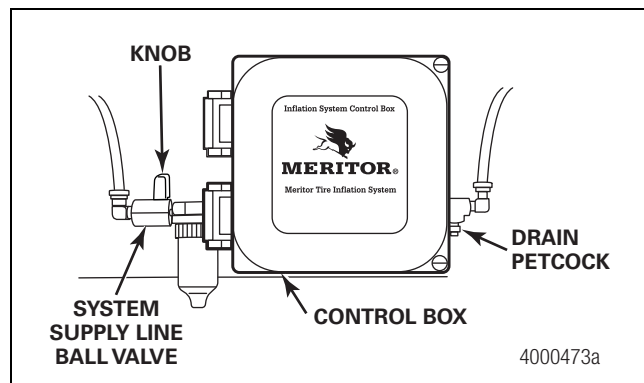

Figure 3.1

3. The tire inflation system must be fully pressurized before proceeding. This may take up to 10 minutes, since the axles, tires and possibly the brake system will have to be pressurized. A shop air source will charge the system more quickly than a tractor compressor.

Fully pressurize the tire inflation system by connecting the trailer to a pressure source that can deliver 20 psi (137.9 kPa) above the control box setting, typically 120-130 psi (827-896 kPa) to the trailer gladhands. Allow the air pressure source sufficient time to pressurize the system, which may take up to 10 minutes.

Check all fittings, hose connections and thru-tee relief valves for air leaks using non-corrosive leak detecting solution.

4. Connect a 12-volt power source to the trailer seven-way box. Figure 3.2.

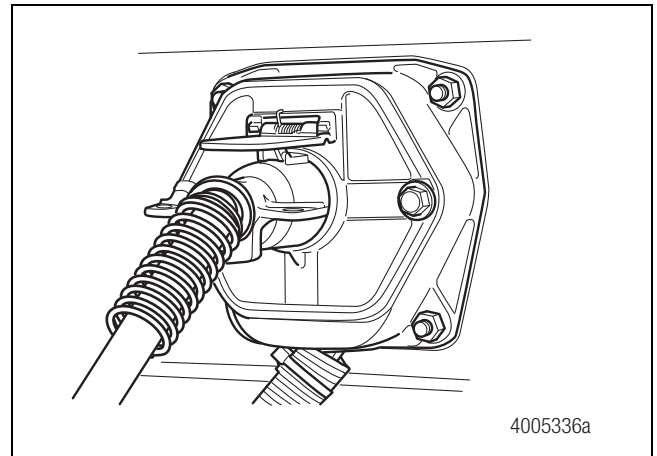

Figure 3.2

5. Check all of the male hose connections at the thru-tee assemblies by pushing a short piece of tire inflation system air line into the fitting. Air should flow from the male hose connection. Figure 3.3.

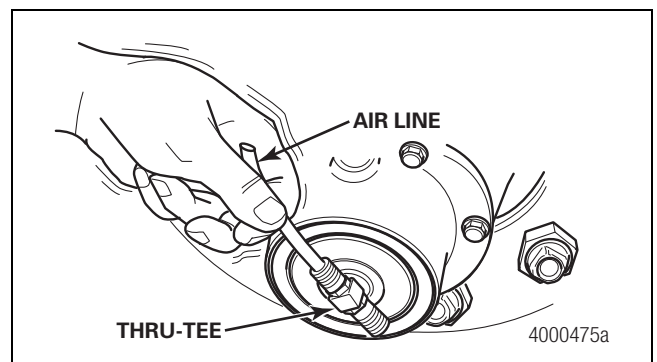

Figure 3.3

6. Check the warning light by opening the drain petcock at the control box. Figure 3.4. The warning light will come ON when the petcock is open and turn OFF when the petcock is closed. Figure 3.1.

3 Check System Operation

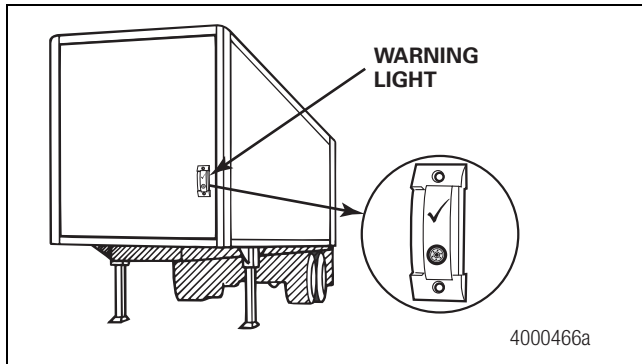

Figure 3.4

7. Push on the check valves at the ends of the hoses attached to the tires. Air should flow from the tires. Figure 3.5.

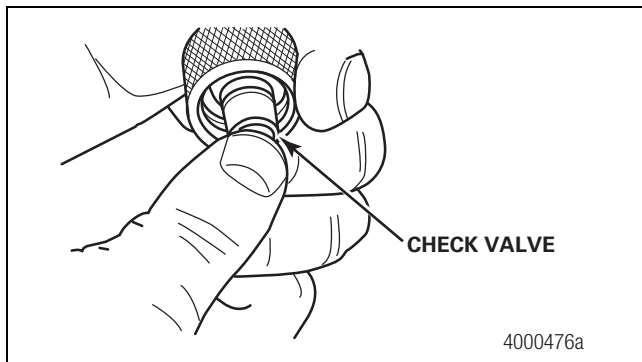

Figure 3.5

8. Use the check valve in the hoses to reduce pressure in all the tires 5 to 10 psi below the desired tire pressure. A sticker located inside the control box door indicates the tire pressure that the inflation system will deliver. Figure 3.6. For example, if the fleet runs 100 psi (689 kPa), reduce the tire pressure to 90 to 95 psi. Figure 3.5.

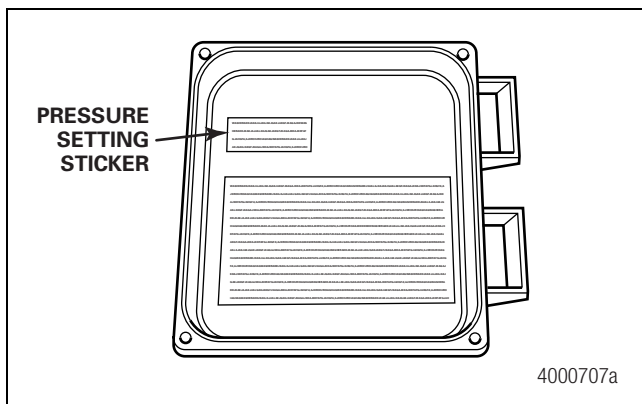

Figure 3.6

9. Choose a tire to test. Hand-tighten the hose to the thru-tee. Figure 3.7.

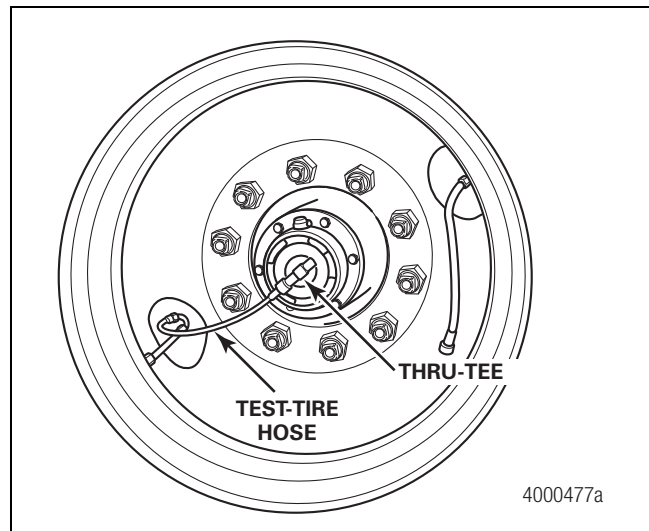

Figure 3.7

10. Allow sufficient time for the pressure to build up in the test-tire. This may take up to 20 minutes, depending on system pressure and other vehicle air requirements.
11. Disconnect the test-tire hose from the thru-tee. Check the test-tire pressure using an accurate air pressure gauge. Tire pressure should equal the system pressure setting on the decal in the control box. Figure 3.8.

- **If the test tire pressure is incorrect:** Check the control box setting and adjust if necessary.

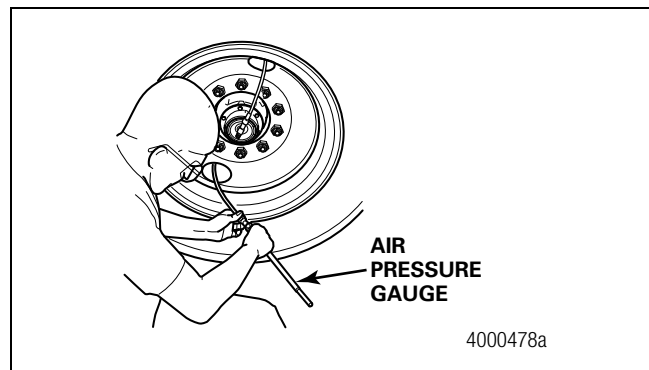

Figure 3.8

3 Check System Operation

Control Box Adjustment Procedures

NOTE: Before attempting to adjust the control box, ensure that you have sufficient air pressure being supplied to the trailer. It is recommended that you have a minimum of 20 psi (137 kPa) above your target tire pressure.

Control Box Pressure Check

1. Obtain a gauge set consisting of a test gauge, a fitting or tubing to attach to the control box and a valve to bleed off pressure. A high-quality gauge is recommended for this process. Figure 3.9 and Figure 3.10.

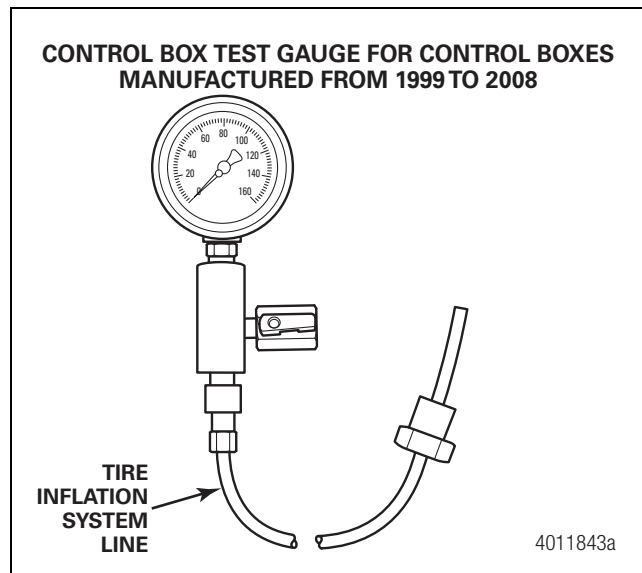

Figure 3.9

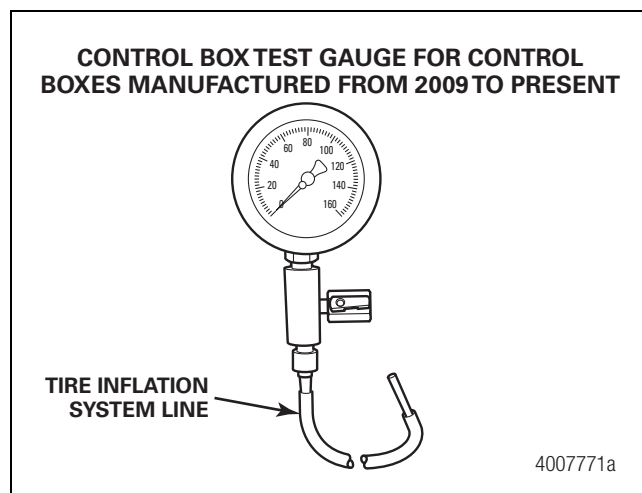

Figure 3.10

2. Turn the supply line ball valve to the closed position. Figure 3.11.

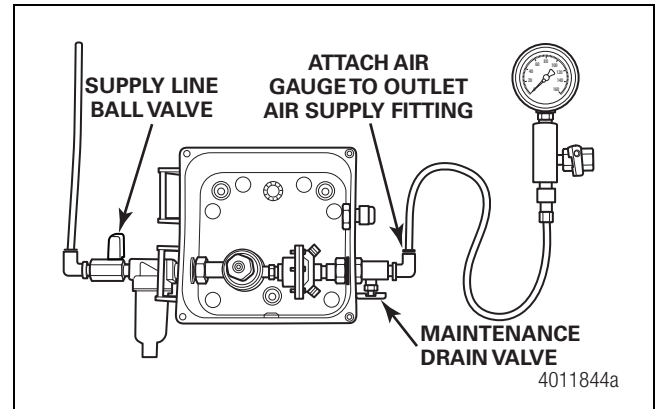

Figure 3.11

3. Open the maintenance drain valve to deplete all air pressure from the system. Close the valve. Figure 3.11.
4. Remove the outlet air supply line from the fitting on the air pressure outlet side of the control box. Connect the test gauge to the outlet air supply fitting. Figure 3.11.
5. Turn the supply line ball valve to the ON position. This allows air to charge the control box system. Figure 3.12.

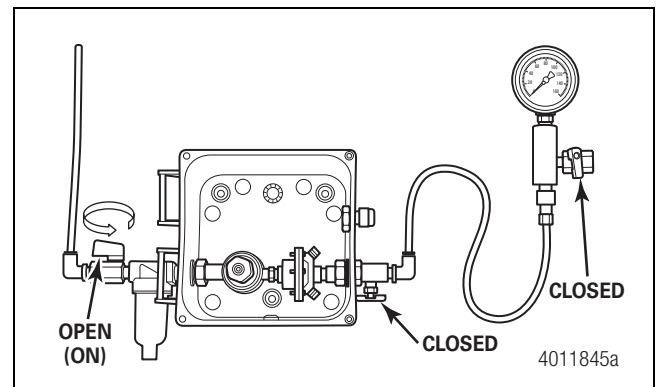

Figure 3.12

6. Read the pressure setting on the gauge. The reading on the gauge should be approximately 3 psi (20 kPa) above the tire target pressure.
 - **If the pressure reading is correct:** Proceed to the next step.
 - **If the pressure setting is incorrect:** Continue to the Regulator Adjusting Procedure.

3 Check System Operation

7. If the pressure setting is correct, complete the following steps.
 - A. Turn the supply line ball valve to the closed position.
 - B. Open the gauge set ball valve to bleed off the pressure.
 - C. Disconnect the test gauge.
 - D. Reconnect the outlet air supply line.
 - E. Turn the supply line ball valve back to the open position.

Regulator Adjusting Procedure

NOTE: During this adjustment procedure, the pressure gauge needle reading should react to the regulator knob movement.

1. Unlock the regulator knob by pulling on the knob outward. You should hear and feel a slight click. Figure 3.13.

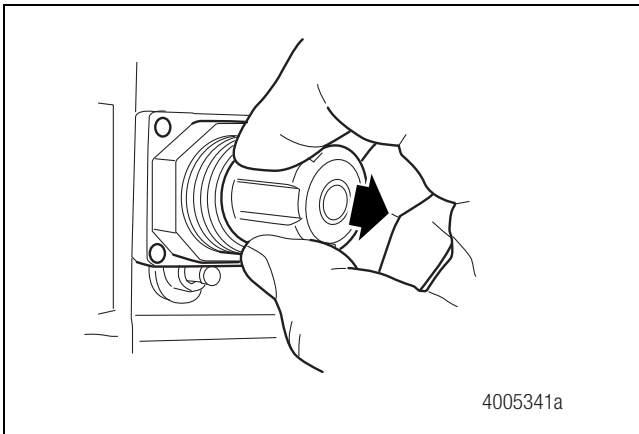

Figure 3.13

2. Turn the regulator knob counter-clockwise until the pressure on the gauge decreases to approximately 60 psi (413 kPa).
3. Slowly increase the pressure by turning the regulator knob clockwise until the gauge has reached 3 psi (20 kPa) above your desired tire target pressure.

NOTE: During the adjustment process, if you increased the pressure beyond your target tire pressure, the pressure must be returned back to approximately 60 psi (413 kPa) before slowly increasing the pressure to your target.

4. Once the target pressure has been achieved, lock the regulator knob by pushing it inward. You should hear and feel a slight click.

5. Perform a Regulator Function Test using the following procedure. A Regulator Function Test should be conducted after making any adjustments.

Regulator Function Test

1. Cycle the regulator with the following steps and observe the gauge as described in Step 2.
 - A. Bleed the gauge set as follows. Figure 3.14.
Close the supply line ball valve.
Open the gauge set ball valve, bleeding off the air.

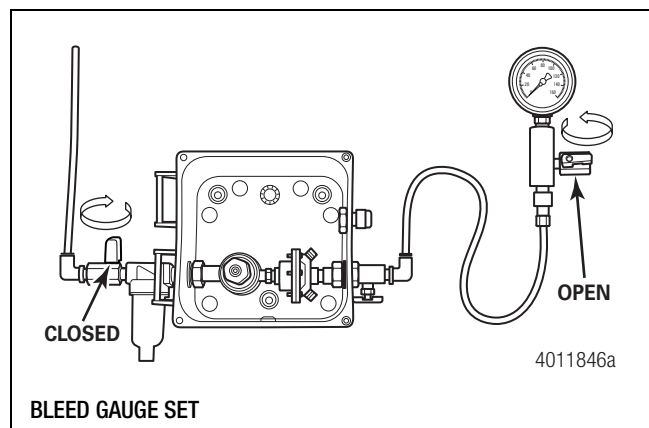

Figure 3.14

- B. Charge the gauge set as follows. Figure 3.15.
Close the gauge set ball valve.
Open the supply line ball valve, charging the gauge set.

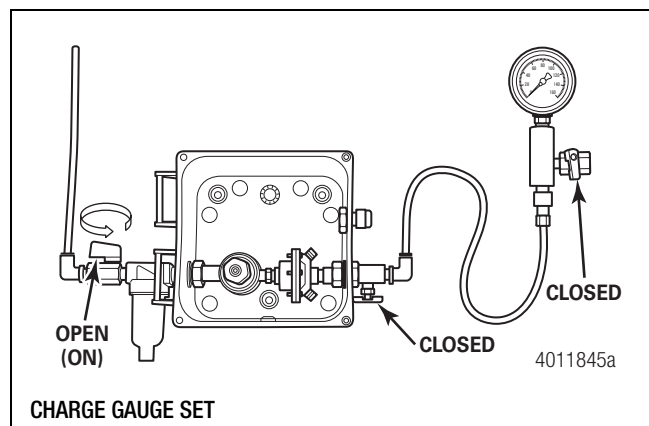

Figure 3.15

3 Check System Operation

2. Observe the gauge needle during the cycling process. The needle should not move sluggishly towards the target pressure setting and should not go past the target pressure.
3. Repeat the above regulator function test steps a minimum of two times and until the gauge pressure reading meets your target pressure every time.
4. If the pressure setting is correct, complete the following steps.
 - A. Turn the supply line ball valve to the closed position.
 - B. Open the gauge set ball valve to bleed off the pressure.
 - C. Disconnect the test gauge. Figure 3.16.
 - D. Reconnect the outlet air supply line. Figure 3.17.
 - E. Turn the supply line ball valve back to the open position.

6. Install a decal inside the control box lid to note the tire pressure change and date of change. Figure 3.18.



Figure 3.18

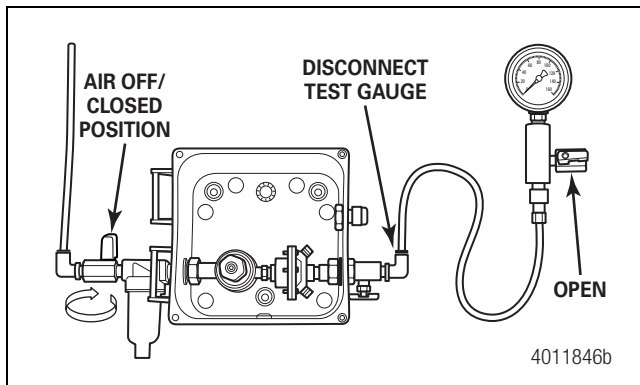

Figure 3.16

7. Close and secure the control box lid with the lid screws.
8. When the test-tire pressure is correct, hand-tighten the remaining tire hoses to the thru-tees. Do not use pliers. The tire inflation system will inflate all of the tires to the specified pressure. At this point, the system is fully assembled. Figure 3.19.

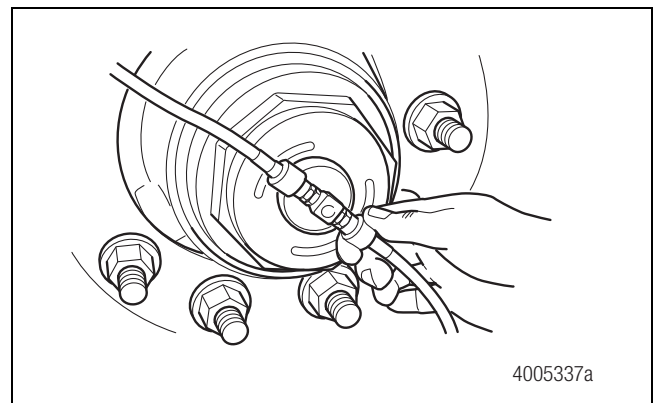

Figure 3.19

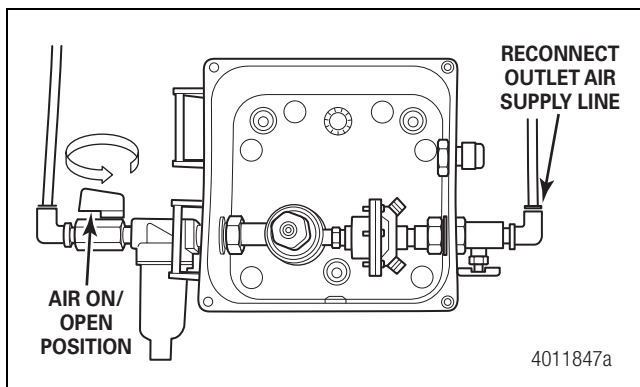

Figure 3.17

5. Upon completion of adjusting the regulator, ensure that all tire pressures are reduced 5-10 psi (34-69 kPa) below the tire target pressure. This will allow the system to fill the tires to the desired target pressure.

- ⚠ CAUTION**
Check the wheel ends to ensure the tire inflation system valve stems and hoses do not contact the wheels or brake drums. Damage to components can result.

9. Check the wheel ends to verify that the tire inflation system hoses do not contact the wheels. Figure 3.20.
 - **If a hose contacts a wheel:** Use a torque wrench set to 55 lb-in (6.2 N•m) to slightly rotate the thru-tee to reposition the hose away from the wheel. **ⓘ**

3 Check System Operation

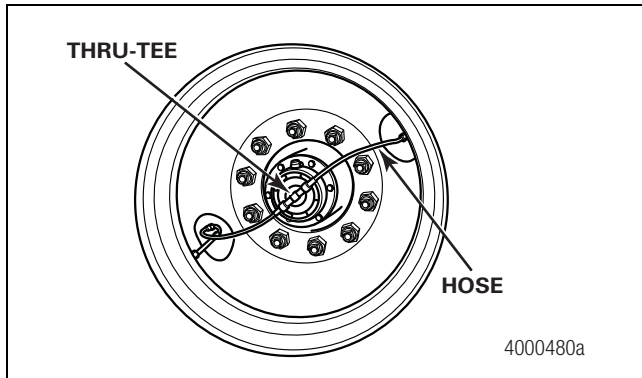

Figure 3.20

MTIS Allowable Leak Rate and Test

All pneumatic systems on commercial vehicles such as brake systems, controls, etc., have allowable leak rates. When MTIS is isolated from all other trailer pneumatic components, the allowable leak rate is as follows.

- **For Single, Tandem, Tri-Axle Trailers and Dollies:** A 1 psi (6.89 kPa) drop in system pressure over a one minute time period is acceptable; any pressure loss greater than 1 psi (6.89 kPa) is unacceptable.

Leak Rate Test

1. Turn the supply line ball valve at the control box assembly to the closed position.
2. Open the maintenance drain valve to deplete all pressure from the system, then close the valve.
3. Install a 1/4" air line fitting tee and a small section of 1/4" air line to the control box outlet port. Figure 3.21.

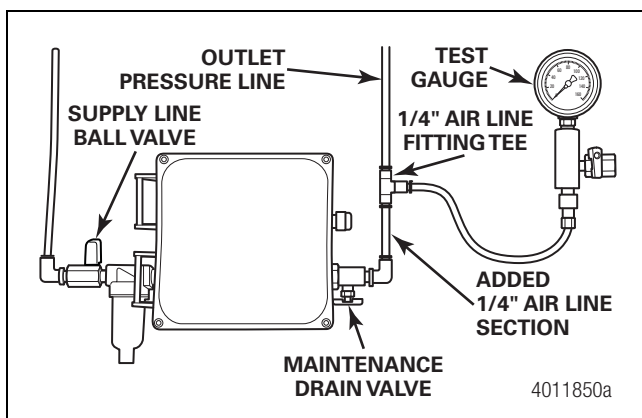

Figure 3.21

4. Install test gauge and outlet pressure line to open ports on the 1/4" air line fitting tee. Figure 3.21.
5. Turn the supply line ball valve to the open position and fully charge the system.
6. Turn the supply line ball valve to the closed position.
7. Record the pressure drop at the test gauge.
 - **If the pressure drop exceeds the acceptable leak rate:** Apply non-corrosive leak detecting solution to all MTIS fittings outside the control box and check for leaks. NOTE: Never apply leak detecting solution on any of the internal components of the control box assembly. All control box assemblies are tested 100% by the manufacturer.
 - **If you suspect the leak is coming from any of the internal control box components:** Contact the Meritor OnTrac™ Customer Call Center at 866-668-7221.
8. When the system has passed the leak test, perform the following.
 - A. Deplete all pressure from system at the test gauge set ball valve.
 - B. Remove the test gauge and 1/4" air line fitting tee and small section of 1/4" air line.
 - C. Reinstall the outlet pressure line.
 - D. Turn the supply line ball valve to the open position.

Check the Hose Connections for Leaks

Use the following procedure to check for and correct system leaks from the tire inflation system fittings and hose connections.

⚠ CAUTION

Test the tire inflation system for air leaks before you place the vehicle into service. Spray a non-corrosive leak detection solution on all fittings and connections. Listen for audible leaks and check for bubbles. If you detect a leak, identify the source and replace parts as required. Air leaks in the tire inflation system can cause damage to components during operation.

1. Test the tire inflation system for air leaks. Spray a non-corrosive leak detection solution on all fittings and hose connections to check for leaks. Figure 3.22 and Figure 3.23.

3 Check System Operation

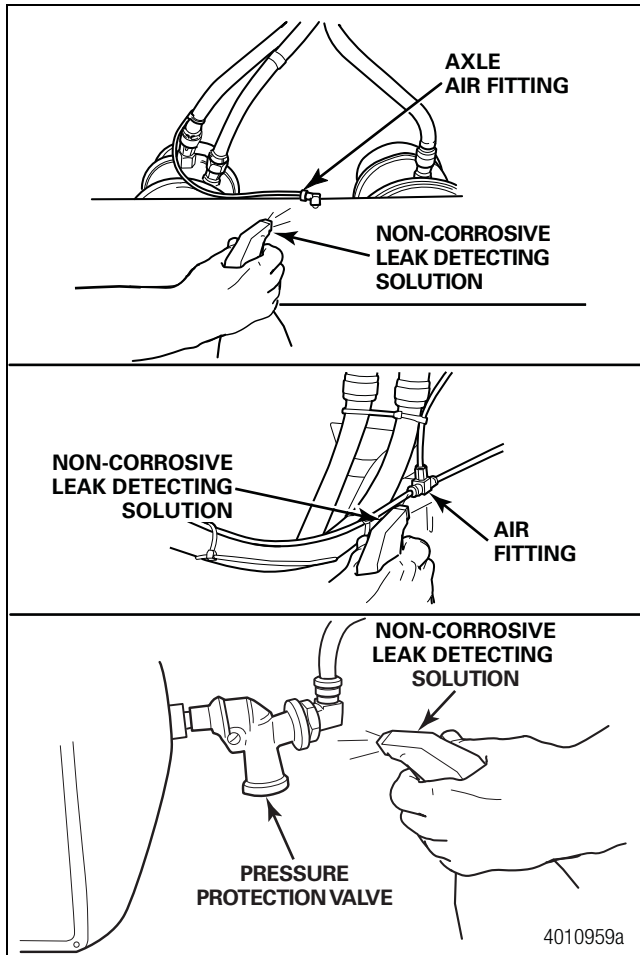

Figure 3.22

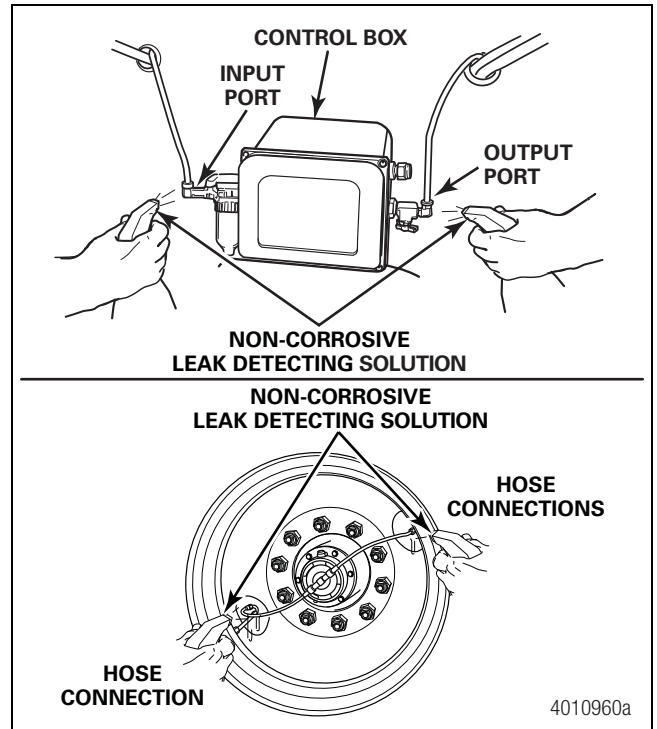

Figure 3.23

2. Look for bubbling and listen for audible leaks.
3. Tighten or replace fittings that leak.

Check the Wheel End for Air Leaks

Use the following procedure to check for, and correct, system air leaks from the tire inflation system components located at the wheel end, including the hoses, thru-tee, stator and axle press plug.

1. Spray a non-corrosive leak detecting solution to check the hose to the thru-tee connection and the hubcap relief valve for leaks. Figure 3.24.

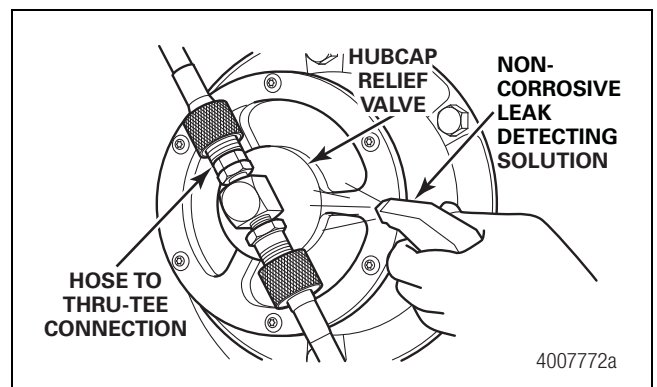

Figure 3.24

3 Check System Operation

2. Look for bubbling and listen for audible leaks.
 - **If the hubcap relief valve is leaking:** The thru-tee, stator or axle press plug is leaking. Use the following procedure to investigate further. Refer to the instructions in this manual for the following steps.
 - A. Turn the tire inflation system off using the ball valve at the control box.
 - B. Drain all the air from the system using the drain petcock at the control box.
 - C. Remove the hoses from the thru-tee. Then remove the thru-tee and hubcap.
 - D. Cover the wheel end with a clean towel to protect the bearings from contaminants.
 - E. Insert the thru-tee into the stator and hold it in place.
 - F. Turn the system ON.
 - G. Ensure to hold the tee straight into the axle. Spray the axle press plug area with a non-corrosive leak detecting solution to check for leaks. Figure 3.25.

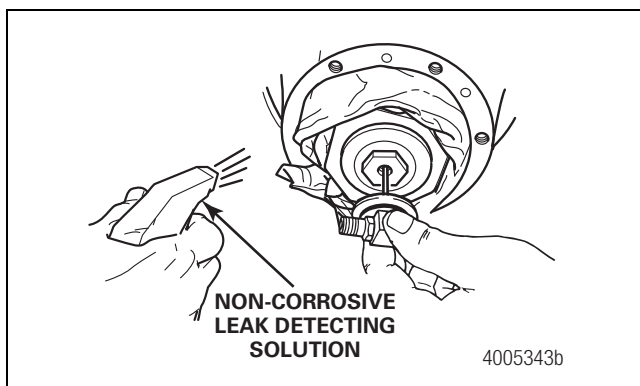



Figure 3.25

- H. Look for bubbling and listen for audible leaks.
 - **If the thru-tee is leaking:** Replace it with a new part. Go to Step L.
 - **If the stator is leaking:** Either tighten the stator or replace it with a new part. Go to Step L.
 - **If the axle press plug is leaking:** Replace the axle press plug with a new part. Go to Step J.
 - **If your system has the ThermALERT system upgrade and the thermal plug is leaking:** Replace the thermal plug by using the following steps.

- I. Remove the thermal plug with a 5/32-inch (4 mm) Allen-head socket. Figure 3.26.
 - Remove the sealing washer.
 - Inspect the sealing surface in the spindle plug area for debris.
 - Install a new sealing washer on a new thermal plug.
 - Install the thermal plug into the spindle plug and tighten to 25-30 lb-in (2.82-3.39 N•m). 

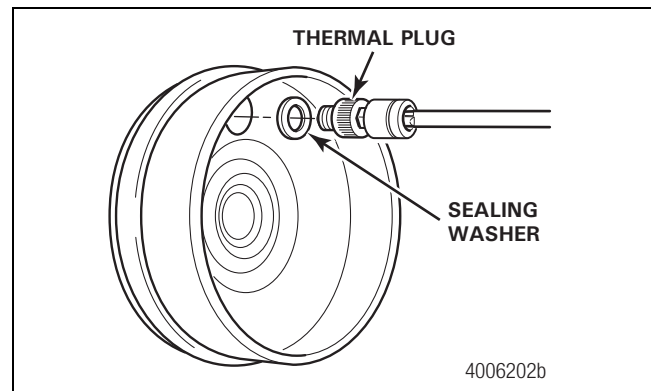

Figure 3.26

- J. Use a slide hammer fitted with the axle press plug removal tool to remove the leaking axle press plug. Use care not to score the inside diameter of the spindle bore. Figure 3.27.

A slide hammer and axle press plug remover is available from Meritor to help remove the axle press plugs. Refer to Section 7. Figure 3.28.

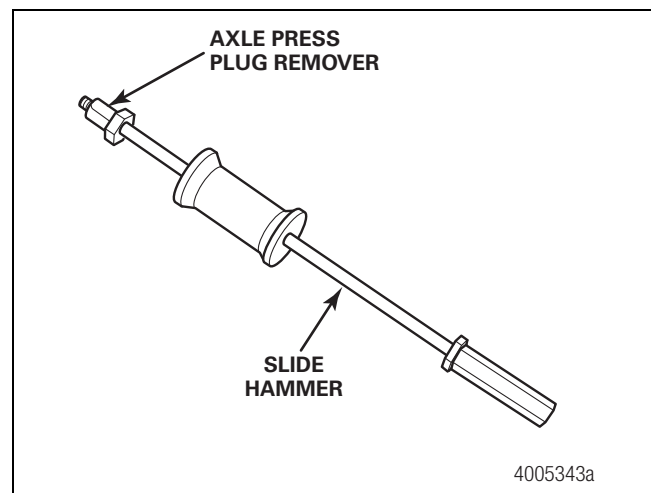

Figure 3.27

3 Check System Operation

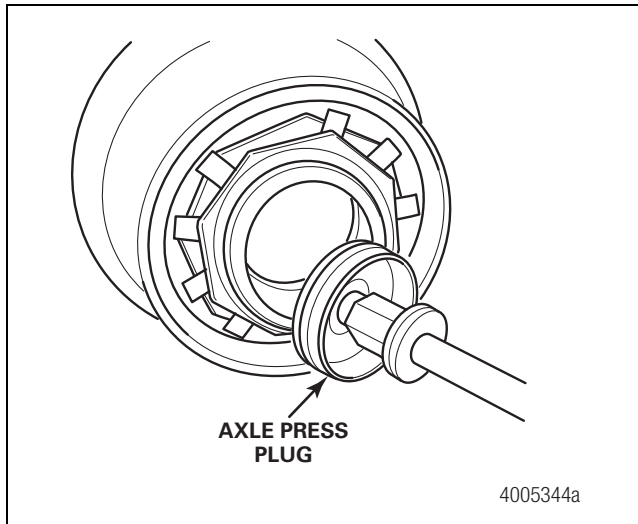

Figure 3.28

- K. Install a new axle press plug. Refer to Step 9 of the Axle Press Plug Installation procedure in this manual.
- L. Reassemble the wheel end and tire inflation system components per the procedures in Section 2 of this manual.

4 Pre-Service Check

Hazard Alert Messages

Read and observe all Warning and Caution hazard alert messages in this publication. They provide information that can help prevent serious personal injury, damage to components, or both.

⚠ WARNING

To prevent serious eye injury, always wear safe eye protection when you perform vehicle maintenance or service.

Pre-Service Check

After receiving a trailer and before placing it in service, check the tire inflation system to ensure it operates correctly.

1. Wear safe eye protection.
2. Check that the trailer has the correct air supply 20 psi (137.9 kPa) above the control box setting 120-130 psi (827-896 kPa) and the system is connected to a 12-volt power source.
3. Check that the system ball valve is open. When the supply line ball valve is open, the knob aligns with the valve body. Ensure that the drain petcock is closed. Figure 4.1.

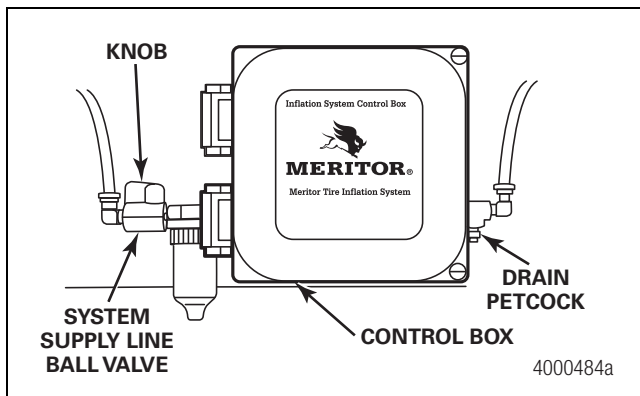

Figure 4.1

4. Check the warning light by opening the drain petcock at the control box. The light will come ON to indicate that it's operating correctly. Figure 4.2.
 - **If the warning light is not operating correctly:** Refer to Section 6.

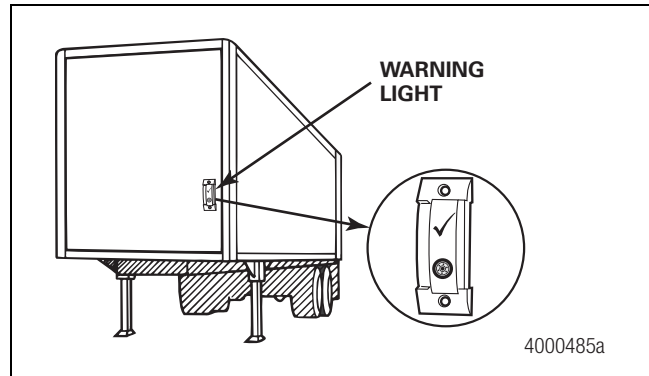

Figure 4.2

5. Use an accurate air pressure gauge to check the tire pressure at the system hoses. Figure 4.3.
 - **If the tire pressure is not correct:** Refer to Section 6.

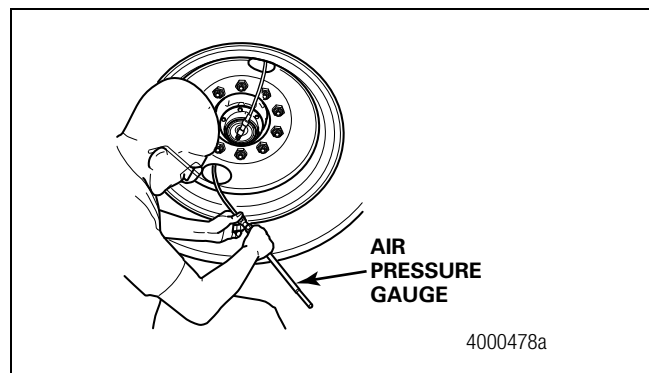

Figure 4.3

6. Use a non-corrosive leak detecting solution to check the hose-to-valve stem connections, hose-to-thru-tee connections and hubcap relief valve for leaks. Figure 4.4. Repair or replace parts as required. Refer to Section 3.

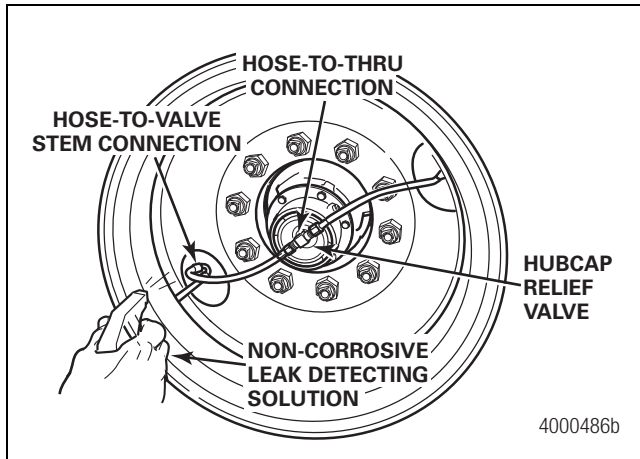

Figure 4.4

⚠ CAUTION

Check the wheel ends to ensure the tire inflation system valve stems and hoses do not contact the wheels or brake drums. Damage to components can result.

7. Check the wheel ends to verify that the tire inflation system hoses do not contact the wheels. Figure 4.5.
 - **If a hose contacts a wheel:** Use a torque wrench set to 55 lb-in (6.2 N•m) to slightly rotate the thru-tee to reposition the hose away from the wheel. **🔧**

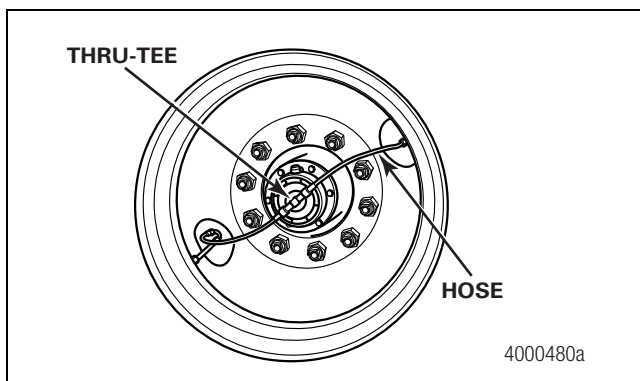

Figure 4.5

5 Inspection and Maintenance

Hazard Alert Messages

Read and observe all Warning and Caution hazard alert messages in this publication. They provide information that can help prevent serious personal injury, damage to components, or both.

⚠ WARNING

To prevent serious eye injury, always wear safe eye protection when you perform vehicle maintenance or service.

Tire Inflation System Inspection Interval Guidelines

Tire inflation system inspection intervals depend on factors such as the environment, mileage, and loading. For example, container chassis service is a light-duty application, because it usually involves an on-highway environment and low mileage. Light-duty applications require extended inspection intervals.

Dump trailer service is a heavy-duty application, because it usually involves an off-highway environment and heavy loading. Heavy-duty applications require reduced inspection intervals.

Installation of a ThermALERT system does not eliminate the need to perform recommended wheel-end maintenance. Inspect the tire inflation system components listed here for correct operation on the following schedule.

General

Inspect the system wheel-end components whenever you remove a tire.

The control box pressure setting must be inspected and re-adjusted, if necessary, after the initial 6 months of service. Refer to Section 3 for the re-adjustment procedure.

Inspect the control box pressure setting every 6-12 months of normal use. Refer to Section 3.

Light-Duty Service

Inspect the system every 100,000 miles or 24 months, whichever comes first.

Standard-Duty Service

Inspect the system every 100,000 miles or 12 months, whichever comes first.

Heavy-Duty Service

Inspect the system every 50,000 miles or six months, whichever comes first.

Inspect the following components for correct operation at the recommended inspection intervals. Refer to Section 3 for inspection instructions.

- Warning light
- Tire hose check valves
- Tire pressure
- Tire hose-to-wheel interference
- Tire hose-to-valve stem connections
- All air line fitting connections from the pressure protection valve to the axle air fitting
- Hubcap relief valves
- Particulate filter. Figure 5.1.

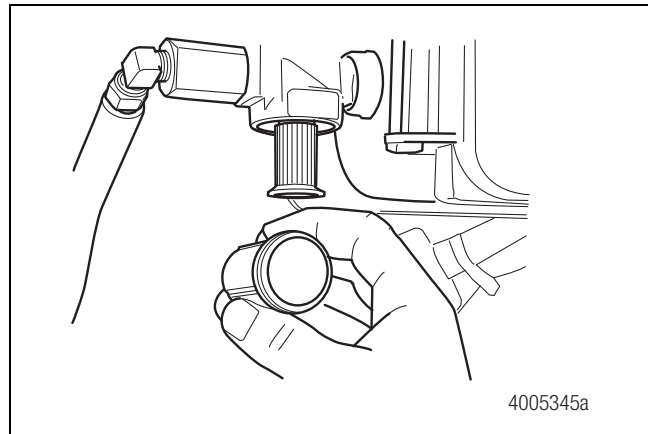

Figure 5.1

Inspection

Warning Light

If the warning light comes ON during operation, the driver should immediately find a safe place to pull over, stop and assess the problem. Inspect the tires and tire inflation system components for leaks. Refer to Section 3. Repair as necessary. Figure 5.2.

The warning light illumination can be caused by one of the following reasons:

- Damaged inflation system components
- System unable to keep up with a leaking tire.

5 Inspection and Maintenance

- Wheel-end temperature is high enough to activate the ThermALERT system.

In the event the ThermALERT system has been activated, an audible sound of air escaping from the hubcap relief valve will alert the driver to the problem wheel end.

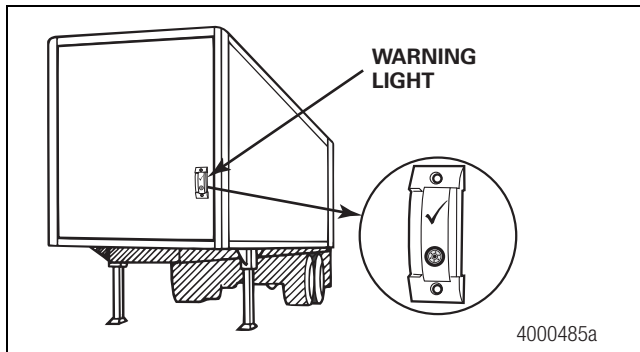

Figure 5.2

During initial system charging, the warning light will come ON and remain ON for up to 10 minutes, depending on the system pressure setting and other vehicle air requirements.

- **If the warning light remains ON for more than 10 minutes during initial system charging:** Refer to Section 6.

Tires

Check the Tire Pressure

Although the tire inflation system can charge a leaking tire during vehicle operation, Meritor recommends that you inspect tires for wear and damage at regular intervals, and check tire pressure at regular intervals as follows.

1. Remove the tire inflation system hose at the thru-tee. Figure 5.3.

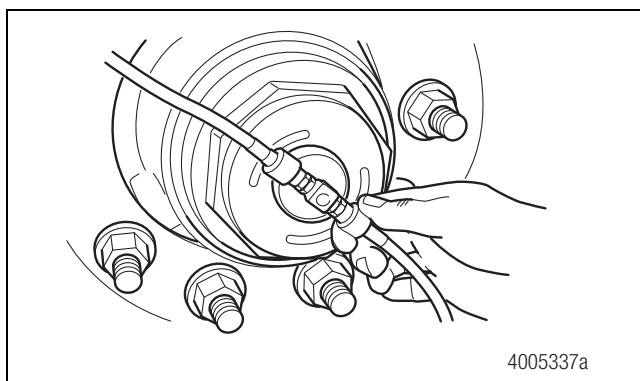

Figure 5.3

2. Press the tire pressure gauge to the hose and read the pressure. The end of the tire inflation system hose incorporates a standard tire valve fitting. Figure 5.4.

- **If the tire pressure is correct:** Reconnect the hose to the thru-tee by hand-tightening the knurled fitting. Do not tighten with pliers.
- **If the tire pressure is not correct:** Refer to the troubleshooting table in Section 6.

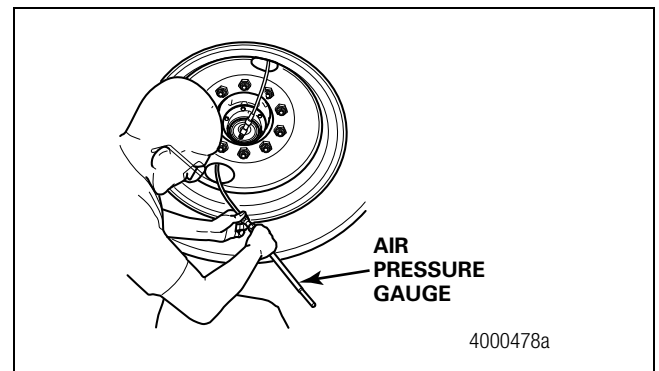

Figure 5.4

Component Removal and Installation

Turn the System OFF

⚠ WARNING

The tire inflation system uses compressed air. Turn the system OFF and drain the system at the drain petcock before you perform maintenance or service to avoid serious personal injury and damage to components.

1. Turn the supply line ball valve to the closed position at the control box to stop air delivery to the system. When the supply line ball valve is closed, the knob is perpendicular to the valve body. Figure 5.5.

5 Inspection and Maintenance

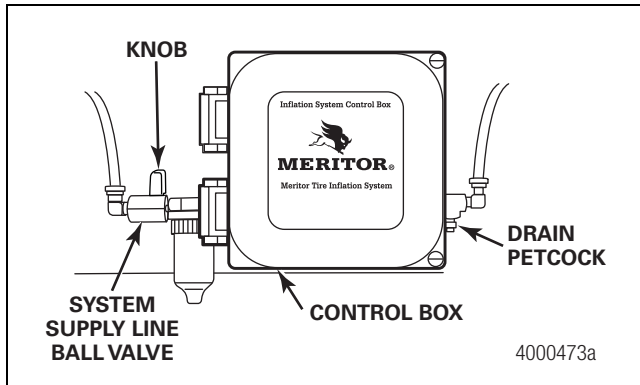

Figure 5.5

2. Open the drain petcock in order to drain the air from the system. Figure 5.5.

Remove and Replace the Tires

⚠ WARNING

Park the vehicle on a level surface. Block the wheels to prevent the vehicle from moving. Support the vehicle with safety stands. Do not work under a vehicle supported only by jacks. Jacks can slip and fall over. Serious personal injury and damage to components can result.

1. Raise the trailer until the tires are off the ground. Place safety stands under the trailer frame or under each trailer axle spring seat. Do not support the vehicle only by jacks. Figure 5.6.

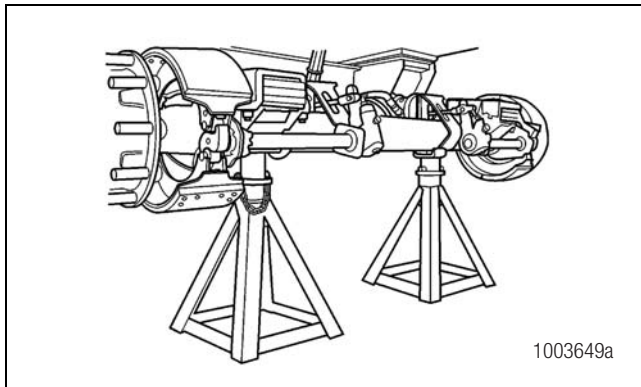

Figure 5.6

2. Remove the tire inflation system hoses.
3. Use a wheel dolly and pull the tire and wheel assembly STRAIGHT off the hub. A wheel dolly will help protect the thru-tee when you remove and replace the tire and wheel assembly. Figure 5.7.

- **If a wheel dolly isn't available:** Meritor recommends that you prevent damage to the thru-tee by turning the system OFF using the drain petcock and system on/off valve as described in this section. Remove the thru-tee, and then remove the tire and wheel assembly.



Figure 5.7

4. Service the tire.
5. Follow the wheel manufacturer's instructions to reinstall the wheels. Verify that the thru-tee fittings point TOWARD the tire valve stems to ensure that you'll be able to correctly route the tire inflation system hoses. Figure 5.8 and Figure 5.9.

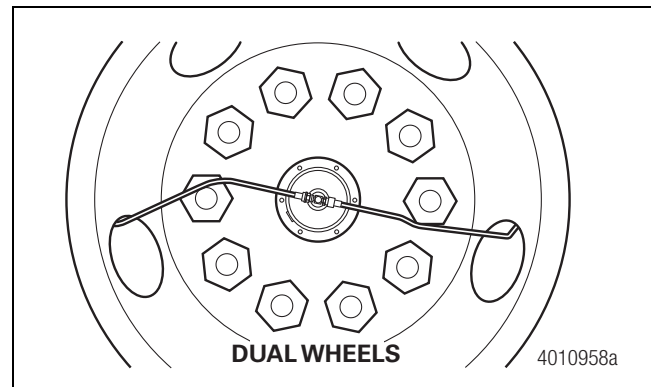

Figure 5.8

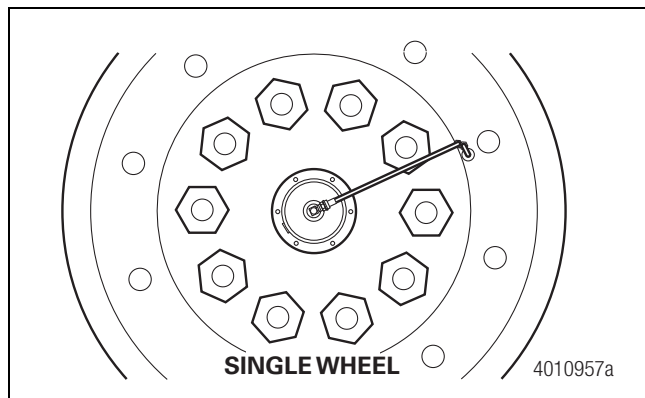

Figure 5.9

6. Reinstall the thru-tee per Step 2 of the Wheel-End Components installation procedure in this section.
7. Install the tire inflation system hoses to the tire valve stems. Refer to Section 2 of this manual.
8. Reduce tire pressure 5-10 psi (0.034-0.069 MPa) below the fleet's tire pressure specification.
9. Hand-tighten the hoses to the thru-tee. Do not use pliers. The tire inflation system will charge the tires to the specified tire setting.
10. Check the hoses for leaks. Refer to Section 3.

Hose Check Valves

CAUTION

Only install Meritor original equipment parts when you service the tire inflation system. Non-original equipment parts will fit the system, but can prevent correct air pressure from being delivered to a leaking tire during operation. Damage to components can result.

Tire inflation system hoses are designed to operate with check valves that open at 3 psi (0.02 MPa) pressure. Only install Meritor original equipment check valves when you replace this part on a tire inflation system hose. Check valves not manufactured by Meritor will fit tire inflation system hoses, but these valves can affect the pressure delivered to the trailer tires. Figure 5.10.

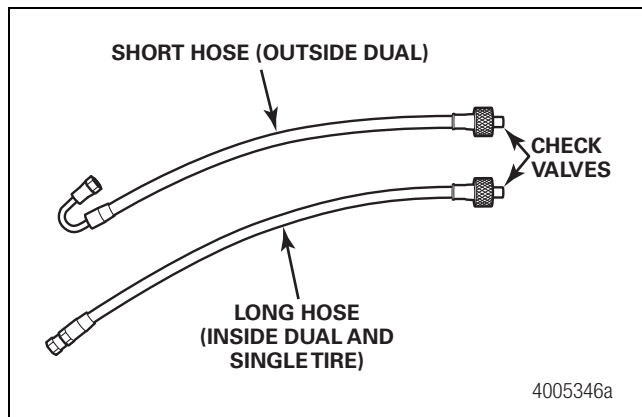

Figure 5.10

Remove the Thru-Tee Before Installing a Hubcap

CAUTION

Do not bend or damage the thru-tee tube when removing and installing a hubcap. A bent thru-tee tube can cause the tire inflation system to leak. Damage to components can result.

Remove the thru-tee before you remove or install a hubcap to prevent bending or damaging the thru-tee tube, which can cause the tire inflation system to leak. Figure 5.11.

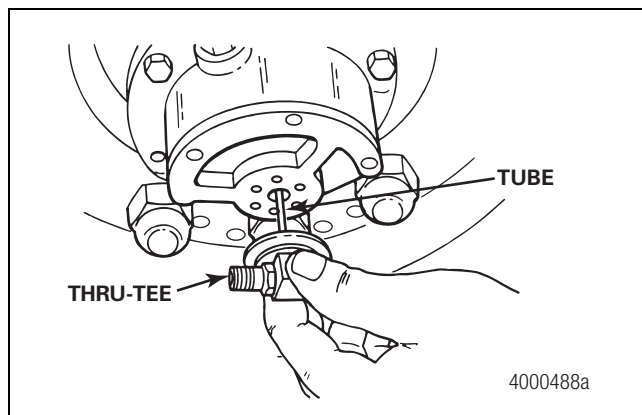

Figure 5.11

5 Inspection and Maintenance

ThermALERT Heat-Sensing Screw Removal and Installation Instructions

⚠ WARNING

If the ThermALERT system activates during vehicle operation, you must repair or replace components that caused the wheel end to overheat before returning the vehicle to service. You also must install a new thermal screw, which is not reusable. Otherwise, the warning light will continue to remain ON during vehicle operation, even though the wheel end has been repaired. If you ignore the warning light, and another wheel end overheats during operation, serious personal injury and damage to components can result.

1. Remove the activated heat-sensing thermal screw using a 5/32-inch (4 mm) Allen key. Figure 5.12.

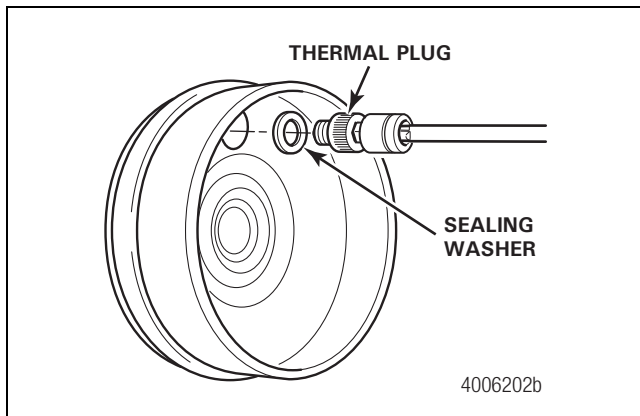

Figure 5.12

2. Remove the sealing washer.
3. Inspect the sealing surface in the spindle plug for debris.
4. Install a new sealing washer on a new thermal screw.
5. Install the thermal screw into the spindle plug and tighten to 25-30 lb-in (2.82-3.39 N•m). **ⓘ**

Hazard Alert Messages

WARNING

To prevent serious eye injury, always wear safe eye protection when you perform vehicle maintenance or service.

Diagnostics

Table B: Troubleshooting

Condition	Possible Causes	Actions
The warning light is ON.	The system is delivering air during initial system charging.	The system is functioning correctly.
	The system is delivering air to a leaking tire.	Repair the tire.
	The system is delivering air to a leaking system component.	Replace the system component.
	The system is delivering air to a cracked axle.	Replace the axle.
The warning light is ON and air is leaking from the wheel-end thru-tee.	The system wiring is incorrect.	Correct the system wiring.
	The trailer is equipped with MTIS™ ThermALERT system and the wheel end is hot.	The system is functioning correctly. Repair and replace wheel-end components.
	The system is delivering air to a leaking system component.	Replace the system component.
	The thru-tee is leaking.	Replace the thru-tee.
	The stator O-ring is leaking.	Replace the stator.
	The stator threads are leaking.	Seal the stator threads.
	The axle press plug is leaking.	Replace the axle press plug.
The warning light is OFF during system operation, with air flowing through the control box.	The trailer is not supplied with 12-volt power.	Supply 12-volt power to the trailer.
	The warning light is inoperative.	Replace the warning light.
	The flow sensing switch is inoperative.	Replace the flow sensing switch.
	The system wiring is damaged.	Repair the system wiring.
The warning light is OFF during system operation and air is leaking from the wheel-end thru-tee.	The system wiring is incorrect.	Correct the system wiring.
	The trailer is equipped with MTIS ThermALERT system, the wheel end is hot and the control box has an incorrect flow switch.	Repair and replace the wheel-end components. Replace the flow switch in the control box with a grey color flow switch.
Air is leaking from the wheel-end thru-tee.	The thru-tee is leaking.	Replace the thru-tee.
	The stator O-ring is leaking.	Replace the stator.
	The stator threads are leaking.	Seal the stator threads.
	The axle press plug is leaking.	Replace the axle press plug.

6 Troubleshooting

Condition	Possible Causes	Actions
Tire pressure is low.	The ball valve is closed. The system pressure setting is too low. The incorrect valve cores are installed.	Open the ball valve. Increase the system pressure setting. Replace the valve cores with Meritor original equipment.
Lubricant is leaking from the wheel-end vent.	The wheel end is overfilled with lubricant. A hubcap without vent extensions is installed onto an oil-lubricated wheel end. The thru-tee is leaking. The stator O-ring is leaking. The stator threads are leaking. The axle press plug is leaking.	Fill the wheel end to the correct level. Install a hubcap with vent extensions. Replace the thru-tee. Replace the stator. Seal the stator threads. Replace the axle press plug.
Tire pressure is high.	The tire is manually over inflated. The system pressure setting is too high.	Reduce the tire pressure. The system will inflate to the correct level. Lower the system pressure setting.
The trailer tire deflates when parked.	The system hose or tire valve stem connection is leaking. The hose valve core is leaking. The tire is leaking.	Correctly tighten the connection or replace the seals. Clean or replace the hose valve core. Repair the tire.
The tire is slow to inflate or no air flows to the tire.	The hose connection to the valve stem may have been overtightened, blocking air flow.	Correctly tighten the connection or replace the hose or seal if it is damaged.

Special Tools

Tire Inflation System

Refer to the following tables for tools and supplies used to service the tire inflation system.

To obtain these tools and supplies, refer to Service Notes page on the front inside cover of this manual.

Spindle Bore Polishers	Part Number	Supplier
Dana/Eaton D22	3T524	Grainger
Hendrickson HN	3T524	
Holland Trade	3T524	
Ingersoll F-22	3T524	
Meritor TN/TQ/TK	3T524	
Meritor MTec6 TN	3T524	
Sudisa 12R/11M	3T524	
Dana/Eaton P22	3T534	
Hendrickson HP	3T534	
Hendrickson TP	3T534	
Holland Propar	3T534	
Meritor TP/TB/WP	3T534	
Meritor MTec6 TP	3T534	

Axle Press Plug Drive Adapters	Part Number	Supplier
Holland Propar	51011-01	Meritor
Dana/Eaton D22	51011-02	
Hendrickson HN	51011-02	
Meritor TN/TQ/TK	51011-02	
Meritor MTec6 TN	51011-20	
Sudisa 9M	51011-09	
Sudisa 12R	51011-03	
Sudisa 11M	51011-04	
Holland Trade	51011-05	
Hendrickson TP	51011-06	
Meritor TP/TB	51011-06	
Meritor MTec6 TP	51011-19	
Meritor WP	51011-07	
Meritor TB Retrofit (Old Style)	51011-14	
Meritor Europe LM	61051-00	
Meritor TL	61051-00	
Dana P-22	51011-13	
Hendrickson HP	51011-13	
Ingersoll F-22	51011-08	
Ingersoll F-24	N/A	

Specialty Tools and Supplies	Part Number	Supplier
Control Box Test Gauge	81014-00	HI-TEC Trailer and Meritor
Drill Jig — Solid Spindle	81023-00	
Tap Guide	81023-10	Meritor
Slide Hammer Kit	81044-00	
Welsh Plug Removal Spear	81044-01	Grainger
Axle Press Plug Remover	81044-02	
Press Plug Drive Handle	51011-10	
Retaining Compound	32621-00	
Towelette	32632-00	
Bore Polishing Mandrel	3T564	
Straight Die Grinder	6Z562	

7 Special Tools

Cleaning Wand

Refer to Figure 7.1 to make a cleaning wand.

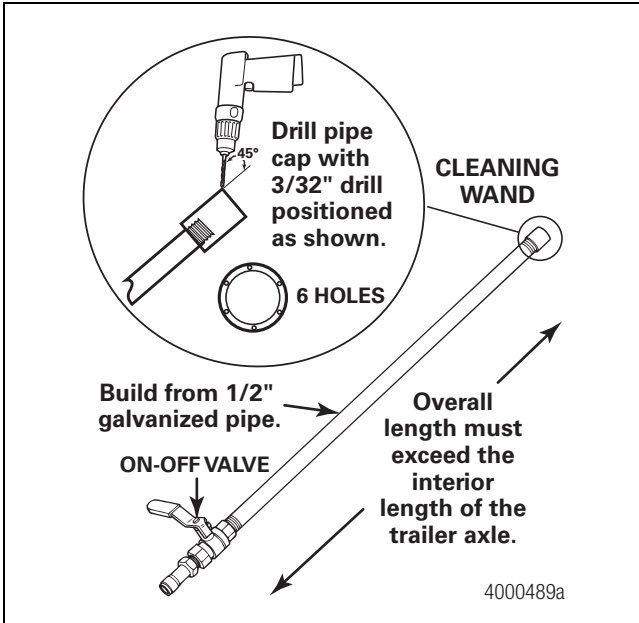

Figure 7.1

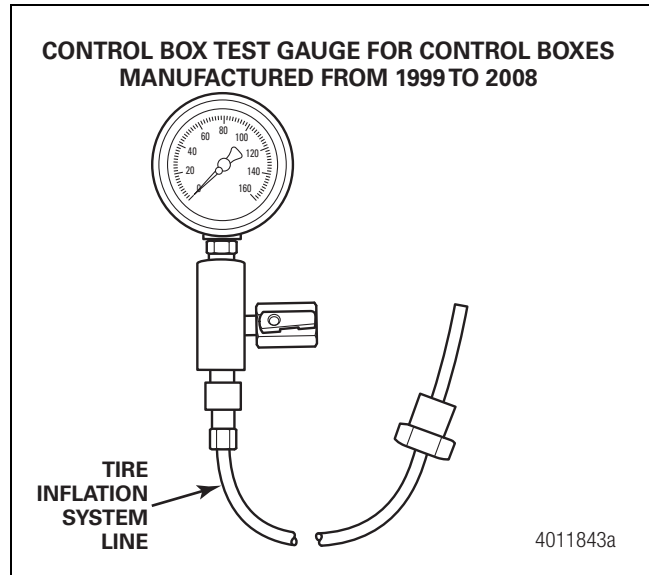

Figure 7.3

Control Box Test Gauge

Refer to Figure 7.2 and Figure 7.3 to assemble a tire test gauge.

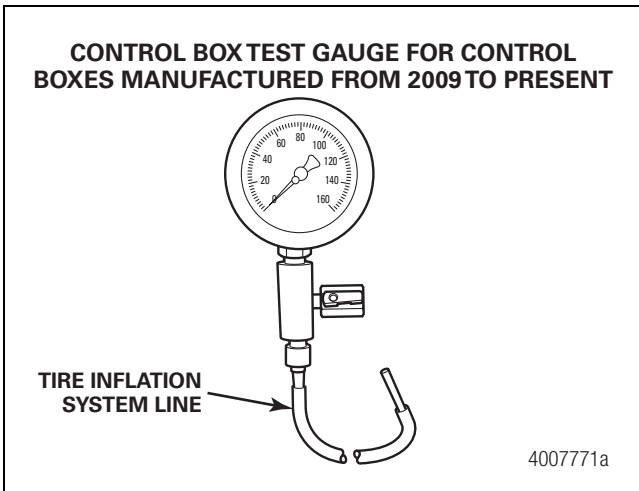

Figure 7.2

Meritor Heavy Vehicle Systems, LLC

2135 West Maple Road

Troy, MI 48084 USA

866-OnTrac1 (668-7221)

meritor.com

Copyright 2017
Meritor, Inc.

Printed in USA

Revised 10-17
Maintenance Manual 14P (16579)

